**User's
Manual**

**Model 761922
Harmonic Analysis Software
for the WT3000**

Product Registration

Thank you for purchasing YOKOGAWA products.

YOKOGAWA provides registered users with a variety of information and services.

Please allow us to serve you best by completing the product registration form accessible from our homepage.

<http://www.yokogawa.com/tm/>

Foreword

Thank you for purchasing the Harmonic Analysis Software (Model 761922). This user's manual lists precautions that must be taken during use, and contains useful information about the functions, and operating procedures of the software. To ensure correct use, please read this manual thoroughly before beginning operation. After reading the manual, keep it in a convenient location for quick reference whenever a question arises during operation. For information about the handling precautions, functions, and operating procedures of WT3000 Precision Power Analyzer (models 760301, 760302, 760303, and 760304) and the handling and operating procedures for Windows, see the manuals for those products.

Notes

- The contents of this manual are subject to change without prior notice as a result of continuing improvements to the instrument's performance and functions. The figures given in this manual may differ from those that actually appear on your screen.
- Every effort has been made in the preparation of this manual to ensure the accuracy of its contents. However, should you have any questions or find any errors, please contact your nearest YOKOGAWA dealer as listed on the back cover of this manual.
- Copying or reproducing all or any part of the contents of this manual without the permission of Yokogawa Electric Corporation is strictly prohibited.
- The TCP/IP software of this product and the document concerning the TCP/IP software have been developed/created by YOKOGAWA based on the BSD Networking Software, Release 1 that has been licensed from California University.

Trademarks

- Microsoft, Windows, Windows NT, Windows Me, and Windows XP are either registered trademarks or trademarks of Microsoft Corporation in the United States and/or other countries.
- Adobe and Acrobat are trademarks of Adobe Systems Incorporated.
- Other company and product names are trademarks or registered trademarks of their respective companies.
- For purposes of this manual, the TM and ® symbols do not accompany their respective trademark names or registered trademark names.

Revisions

- 1st Edition March 2006

Terms and Conditions of the Software License

NOTICE - PLEASE READ CAREFULLY BEFORE USE

Thank you very much for purchasing this medium containing a software program and related documentation provided by Yokogawa Electric Corporation (hereinafter called "Yokogawa"), and the program contained, embedded, inserted or used in the medium (hereinafter called the "Yokogawa Software Program").

By opening this package or plastic wrapping (hereinafter called "Package") enclosing the Yokogawa Software Program, you acknowledge that you understand and agree to the "Terms and Conditions of the Software License" (hereinafter called "Terms and Conditions") which is written in the documentation and separately attached. Accordingly, the Terms and Conditions bind you.

The Yokogawa Software Program and its related documentation including ownership of copyright shall remain the exclusive property of Yokogawa or those third parties from whom sublicensed software in the Yokogawa Software Program is licensed.

Yokogawa hereby grants you permission to use the Yokogawa Software Program on the conditions that you agree to the Terms and Conditions before you open the Package and/or install it in or onto a computer.

IF YOU DO NOT AGREE TO THE TERMS AND CONDITIONS, YOU CANNOT OPEN THE PACKAGE, AND MUST IMMEDIATELY RETURN IT TO YOKOGAWA OR ITS DESIGNATED PARTY.

Terms and Conditions of the Software License

Yokogawa Electric Corporation, a Japanese corporation (hereinafter called "Yokogawa"), grants permission to use this Yokogawa Software Program (hereinafter called the "Licensed Software") to the Licensee on the conditions that the Licensee agrees to the terms and conditions stipulated in Article 1 hereof.

You, as the Licensee (hereinafter called "Licensee"), shall agree to the following terms and conditions for the software license (hereinafter called the "Agreement") based on the use intended for the Licensed Software.

Please note that Yokogawa grants the Licensee permission to use the Licensed Software under the terms and conditions herein and in no event shall Yokogawa intend to sell or transfer the Licensed Software to the Licensee.

Licensed Software Name: Harmonic Analysis Software Model 761922

Number of License: 1

Article 1 (Scope Covered by these Terms and Conditions)

- 1.1 The terms and conditions stipulated herein shall be applied to any Licensee who purchases the Licensed Software on the condition that the Licensee consents to agree to the terms and conditions stipulated herein.
- 1.2 The "Licensed Software" herein shall mean and include all applicable programs and documentation, without limitation, all proprietary technology, algorithms, and know-how such as a factor, invariant or process contained therein.

Article 2 (Grant of License)

- 2.1 Yokogawa grants the Licensee, for the purpose of single use, non-exclusive and non-transferable license of the Licensed Software with the license fee separately agreed upon by both parties.
- 2.2 The Licensee is, unless otherwise agreed in writing by Yokogawa, not entitled to copy, change, sell, distribute, transfer, or sublicense the Licensed Software.
- 2.3 The Licensed Software shall not be copied in whole or in part except for keeping one (1) copy for back-up purposes. The Licensee shall secure or supervise the copy of the Licensed Software by the Licensee itself with great, strict, and due care.
- 2.4 In no event shall the Licensee dump, reverse assemble, reverse compile, or reverse engineer the Licensed Software so that the Licensee may translate the Licensed Software into other programs or change it into a man-readable form from the source code of the Licensed Software. Unless otherwise separately agreed by Yokogawa, Yokogawa shall not provide the Licensee the source code for the Licensed Software.
- 2.5 The Licensed Software and its related documentation shall be the proprietary property or trade secret of Yokogawa or a third party which grants Yokogawa the rights. In no event shall the Licensee be transferred, leased, sublicensed, or assigned any rights relating to the Licensed Software.
- 2.6 Yokogawa may use or add copy protection in or onto the Licensed Software. In no event shall the Licensee remove or attempt to remove such copy protection.
- 2.7 The Licensed Software may include a software program licensed for re-use by a third party (hereinafter called "Third Party Software", which may include any software program from affiliates of Yokogawa made or coded by themselves.) In the case that Yokogawa is granted permission to sublicense to third parties by any licensors (sub-licensor) of the Third Party Software pursuant to different terms and conditions than those stipulated in this Agreement, the Licensee shall observe such terms and conditions of which Yokogawa notifies the Licensee in writing separately.
- 2.8 In no event shall the Licensee modify, remove or delete a copyright notice of Yokogawa and its licensor contained in the Licensed Software, including any copy thereof.

Article 3 (Restriction of Specific Use)

- 3.1 The Licensed Software shall not be intended specifically to be designed, developed, constructed, manufactured, distributed or maintained for the purpose of the following events:
 - a) Operation of any aviation, vessel, or support of those operations from the ground;
 - b) Operation of nuclear products and/or facilities;
 - c) Operation of nuclear weapons and/or chemical weapons and/or biological weapons; or
 - d) Operation of medical instrumentation directly utilized for humankind or the human body.
- 3.2 Even if the Licensee uses the Licensed Software for the purposes in the preceding Paragraph 3.1, Yokogawa has no liability to or responsibility for any demand or damage arising out of the use or operations of the Licensed Software, and the Licensee agrees, on its own responsibility, to solve and settle the claims and damages and to defend, indemnify or hold Yokogawa totally harmless, from or against any liabilities, losses, damages and expenses (including fees for recalling the Products and reasonable attorney's fees and court costs), or claims arising out of and related to the above-said claims and damages.

Article 4 (Warranty)

- 4.1 The Licensee shall agree that the Licensed Software shall be provided to the Licensee on an "as is" basis when delivered. If defect(s), such as damage to the medium of the Licensed Software, attributable to Yokogawa is found, Yokogawa agrees to replace, free of charge, any Licensed Software on condition that the defective Licensed Software shall be returned to Yokogawa's specified authorized service facility within seven (7) days after opening the Package at the Licensee's expense. As the Licensed Software is provided to the Licensee on an "as is" basis when delivered, in no event shall Yokogawa warrant that any information on or in the Licensed Software, including without limitation, data on computer programs and program listings, be completely accurate, correct, reliable, or the most updated.
- 4.2 Notwithstanding the preceding Paragraph 4.1, when third party software is included in the Licensed Software, the warranty period and terms and conditions that apply shall be those established by the provider of the third party software.

- 4.3 When Yokogawa decides in its own judgement that it is necessary, Yokogawa may from time to time provide the Licensee with Revision upgrades and Version upgrades separately specified by Yokogawa (hereinafter called "Updates").
- 4.4 Notwithstanding the preceding Paragraph 4.3, in no event shall Yokogawa provide Updates where the Licensee or any third party conducted renovation or improvement of the Licensed Software.
- 4.5 THE FOREGOING WARRANTIES ARE EXCLUSIVE AND IN LIEU OF ALL OTHER WARRANTIES OF QUALITY AND PERFORMANCE, WRITTEN, ORAL, OR IMPLIED, AND ALL OTHER WARRANTIES INCLUDING ANY IMPLIED WARRANTIES OF MERCHANTABILITY OR FITNESS FOR A PARTICULAR PURPOSE ARE HEREBY DISCLAIMED BY YOKOGAWA AND ALL THIRD PARTIES LICENSING THIRD PARTY SOFTWARE TO YOKOGAWA.
- 4.6 Correction of nonconformity in the manner and for the period of time provided above shall be the Licensee's sole and exclusive remedy for any failure of Yokogawa to comply with its obligations and shall constitute fulfillment of all liabilities of Yokogawa and any third party licensing the Third Party Software to Yokogawa (including any liability for direct, indirect, special, incidental or consequential damages) whether in warranty, contract, tort (including negligence but excluding willful conduct or gross negligence by Yokogawa) or otherwise with respect to or arising out of the use of the Licensed Software.

Article 5 (Infringement)

- 5.1 If and when any third party should demand injunction, initiate a law suit, or demand compensation for damages against the Licensee under patent right (including utility model right, design patent, and trade mark), copy right, and any other rights relating to any of the Licensed Software, the Licensee shall notify Yokogawa in writing to that effect without delay.
- 5.2 In the case of the preceding Paragraph 5.1, the Licensee shall assign to Yokogawa all of the rights to defend the Licensee and to negotiate with the claiming party. Furthermore, the Licensee shall provide Yokogawa with necessary information or any other assistance for Yokogawa's defense and negotiation. If and when such a claim should be attributable to Yokogawa, subject to the written notice to Yokogawa stated in the preceding Paragraph 5.1, Yokogawa shall defend the Licensee and negotiate with the claiming party at Yokogawa's cost and expense and be responsible for the final settlement or judgment granted to the claiming party in the preceding Paragraph 5.1.
- 5.3 When any assertion or allegation of the infringement of the third party's rights defined in Paragraph 5.1 is made, or when at Yokogawa's judgment there is possibility of such assertion or allegation, Yokogawa will, at its own discretion, take any of the following countermeasures at Yokogawa's cost and expense.
 - a) To acquire the necessary right from a third party which has lawful ownership of the right so that the Licensee will be able to continue to use the Licensed Software;
 - b) To replace the Licensed Software with an alternative one which avoids the infringement; or
 - c) To remodel the Licensed Software so that the Licensed Software can avoid the infringement of such third party's right.
- 5.4 If and when Yokogawa fails to take either of the countermeasures as set forth in the preceding subparagraphs of Paragraph 5.3, Yokogawa shall indemnify the Licensee only by paying back the price amount of the Licensed Software which Yokogawa has received from the Licensee. THE FOREGOING PARAGRAPHS STATE THE ENTIRE LIABILITY OF YOKOGAWA AND ANY THIRD PARTY LICENSING THIRD PARTY SOFTWARE TO YOKOGAWA WITH RESPECT TO INFRINGEMENT OF THE INTELLECTUAL PROPERTY RIGHTS INCLUDING BUT NOT LIMITED TO, PATENT AND COPYRIGHT.

Article 6 (Liabilities)

- 6.1 If and when the Licensee should incur any damage relating to or arising out of the Licensed Software or service that Yokogawa has provided to the Licensee under the conditions herein due to a reason attributable to Yokogawa, Yokogawa shall take actions in accordance with this Agreement. However, in no event shall Yokogawa be liable or responsible for any special, incidental, consequential and/or indirect damage, whether in contract, warranty, tort, negligence, strict liability, or otherwise, including, without limitation, loss of operational profit or revenue, loss of use of the Licensed Software, or any associated products or equipment, cost of capital, loss or cost of interruption of the Licensee's business, substitute equipment, facilities or services, downtime costs, delays, and loss of business information, or claims of customers of Licensee or other third parties for such or other damages. Even if Yokogawa is liable or responsible for the damages attributable to Yokogawa and to the extent of this Article 6, Yokogawa's liability for the Licensee's damage shall not exceed the price amount of the Licensed Software or service fee which Yokogawa has received. Please note that Yokogawa shall be released or discharged from part or all of the liability under this Agreement if the Licensee modifies, remodels, combines with other software or products, or causes any deviation from the basic specifications or functional specifications, without Yokogawa's prior written consent.
- 6.2 All causes of action against Yokogawa arising out of or relating to this Agreement or the performance or breach hereof shall expire unless Yokogawa is notified of the claim within one (1) year of its occurrence.
- 6.3 In no event, regardless of cause, shall Yokogawa assume responsibility for or be liable for penalties or penalty clauses in any contracts between the Licensee and its customers.

Article 7 (Limit of Export)

Unless otherwise agreed by Yokogawa, the Licensee shall not directly or indirectly export or transfer the Licensed Software to any countries other than those where Yokogawa permits export in advance.

Article 8 (Term)

This Agreement shall become effective on the date when the Licensee receives the Licensed Software and continues in effect unless or until terminated as provided herein, or the Licensee ceases using the Licensed Software by itself or with Yokogawa's thirty (30) days prior written notice to the Licensee.

Article 9 (Injunction for Use)

During the term of this Agreement, Yokogawa may, at its own discretion, demand injunction against the Licensee in case that Yokogawa deems that the Licensed Software is used improperly or under severer environments other than those where Yokogawa has first approved, or any other condition which Yokogawa may not permit.

Article 10 (Termination)

Yokogawa, at its sole discretion, may terminate this Agreement without any notice or reminder to the Licensee if the Licensee violates or fails to perform this Agreement. However, Articles 5, 6, and 11 shall survive even after the termination.

Article 11 (Jurisdiction)

Any dispute, controversies, or differences between the parties hereto as to interpretation or execution of this Agreement shall be resolved amicably through negotiation between the parties upon the basis of mutual trust. Should the parties fail to agree within ninety (90) days after notice from one of the parties to the other, both parties hereby irrevocably submit to the exclusive jurisdiction of the Tokyo District Court (main office) in Japan for settlement of the dispute.

Article 12 (Governing Law)

This Agreement shall be governed by and construed in accordance with the laws of Japan. The Licensee expressly agrees to waive absolutely and irrevocably and to the fullest extent permissible under applicable law any rights against the laws of Japan which it may have pursuant to the Licensee's local law.

Article 13 (Severability)

In the event that any provision hereof is declared or found to be illegal by any court or tribunal of competent jurisdiction, such provision shall be null and void with respect to the jurisdiction of that court or tribunal and all the remaining provisions hereof shall remain in full force and effect.

Contents

Foreword	i
Terms and Conditions of the Software License	ii
Chapter 1 Product Overview	
1.1 Explanation of Functions	1-1
1.2 System Requirements	1-7
1.3 Applicable Standards	1-8
1.4 Flow of Operation (GP-IB)	1-12
1.5 Flow of Operation (Ethernet : WT3000 Option)	1-14
1.6 Terminology Related to Harmonics	1-16
Chapter 2 Preparation before Use	
2.1 Connecting the WT3000 and the PC	2-1
2.2 Setting the GP-IB Control	2-3
2.3 Setting the Ethernet Control	2-5
2.4 Installing the Software	2-7
2.5 Starting and Exiting the Software	2-10
Chapter 3 Retrieving and Loading Measured Data/Waveform Data to Be Evaluated	
3.1 Initializing the Communication Interface	3-1
3.2 Enabling On-Line Mode	3-3
3.3 Setting the Measurement Conditions of the WT	3-4
3.4 Setting the Measurement Mode to Harmonic Measurement	3-5
3.5 Setting the Standard and Measurement Environment	3-6
3.6 Setting the Measurement Time	3-12
3.7 Starting and Stopping Measurements (Retrieving Measured Data/Waveform Data)	3-13
3.8 Switching to Off-Line Mode (Switching from On-Line Mode to Off-Line Mode)	3-16
3.9 Loading Setup Information, Measured Data, and Waveform Data	3-17
Chapter 4 Displaying the Evaluation Results and Measured Data/Waveform Data	
4.1 Displaying the Evaluation Results over the Entire Measurement Time	4-1
4.2 Displaying the Bar Graph of Harmonic Current/Voltage	4-5
4.3 Displaying the List of Harmonic Current/Voltage	4-13
4.4 Displaying the Bar Graph of the Harmonic Current Fluctuation	4-19
4.5 Displaying the Voltage/Current Waveforms	4-23
4.6 Displaying the Graph of Voltage, Current, and Power	4-26
4.7 Displaying the Bar Graph of the Harmonic Phase Angle	4-30
4.8 Displaying the List of the Harmonic Phase Angle	4-32
Chapter 5 Harmonic Monitor and Waveform Monitor	
5.1 Monitoring Harmonics	5-1
5.2 Monitoring Waveforms	5-9

Chapter 6 Loading/Saving Data and Repeatability of Measured Data		1
6.1 Saving Setup Information, Measured Data, and Waveform Data	6-1	
6.2 Loading Setup Information, Measured Data, and Waveform Data	6-4	2
6.3 Saving Harmonic Measurement Data in CSV Format	6-7	
6.4 Saving Waveform Data in CSV Format	6-9	
6.5 Checking the Repeatability of the Measured Data	6-11	
Chapter 7 Saving/Printing Screen Images and Reports		3
7.1 Saving Screen Image Data in BMP Format	7-1	
7.2 Setting Titles/Comments of Reports and Saving Reports in BMP Format	7-3	
7.3 Setting the Printer	7-7	4
7.4 Previewing the Printout	7-8	
7.5 Printing	7-11	
Chapter 8 Setting WT Measurement Conditions		5
8.1 Setting the Measurement Conditions of the WT3000	8-1	
Chapter 9 Other Functions		6
9.1 Cascading/Tiling Graph and List Windows	9-1	
9.2 Arranging Icons	9-3	
9.3 Using the Help Function	9-4	
9.4 Viewing Version Information	9-6	
Chapter 10 Specifications		7
Specifications	10-1	
Index		8
		9
		10
		Index

1.1 Explanation of Functions

This software application (761922) measures harmonic currents of electrical equipment according to an applicable IEC standard, (see section 1.3 for an overview) and displays/saves the results of evaluations made according to the standard.

Applicable Measurement Instruments

This software can be used with Yokogawa's measurement instruments listed below. This user's manual (IM761922-02E) describes the case when this software is used in combination with the WT3000. For information regarding the case when WT1600 or WT2000 series is used, see IM761922-01E. For information about the handling precautions, functions, and operating procedures of each WT, see the respective manuals.

Product	Model
WT3000	760301, 760302, 760303, and 760304
WT1600	760101
WT2000 series	253101, 253102, and 253103

Applicable Standard

For the applicable standards, see section 1.3.

Retrieving and Loading of Measured Data/Waveform Data to Be Evaluated

Setting WT Measurement Conditions

This software application can be used to enter the same harmonic measurement conditions that you can enter using the front panel keys of the WT.

Retrieving Measured Data from the WT Connected On-Line (On-Line Mode)

The measured data to be evaluated against the standard can be retrieved into your PC via the GP-IB or Ethernet interface while making harmonic measurements on the WT.

Loading Measured Data Already Saved (Off-Line Mode)

The measured data retrieved by the software can be saved. The saved measured data/waveform data can be loaded to be evaluated against the standard.

Measurement Modes

This software has three measurement modes: Harmonic Measurement, Harmonic Monitor, and Waveform Monitor. The type of data retrieved and the operation vary depending on the measurement mode.

Harmonic Measurement Mode

- **When in On-Line Mode**

Measurement and evaluation of harmonics conforming to “IEC 61000-3-2 Edition 2.2” or JIS can be made while making harmonic measurements on the WT.

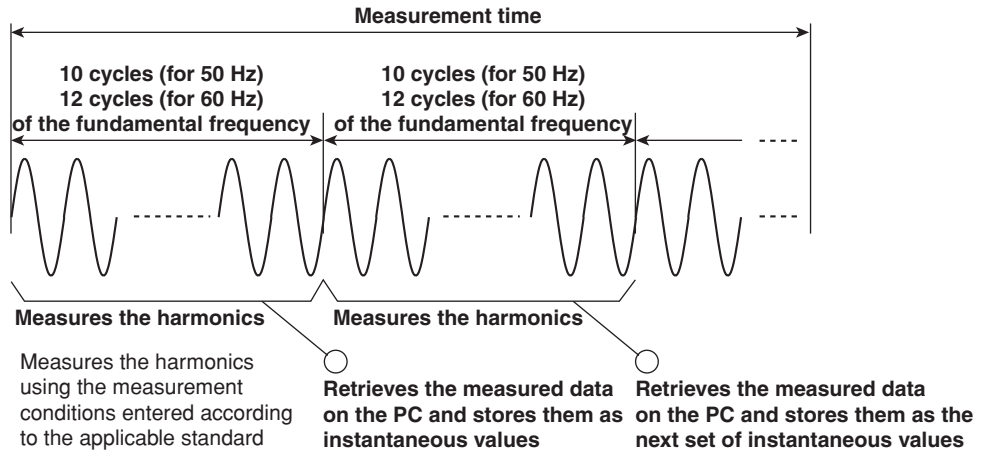

One set of harmonic measurement data (handled as instantaneous values by the software) consists of harmonic data measured every 200 ms (10 cycles for 50 Hz and 12 cycles for 60 Hz). The instantaneous values, the mean value, and the maximum value of the measured data retrieved within the measurement time (see next page) can be evaluated to determine whether they are within the limits of the standard.

- **When in Off-Line Mode**

Evaluation can be made on the loaded measurement data according to the method complying with IEC 61000-3-2 Edition 2.2 or JIS.

Harmonic Monitor Mode

This mode can be selected only when in On-Line mode. Harmonic fluctuation can be monitored on bar graphs and a numerical list while making harmonic measurements on the WT. This mode is used to monitor the conditions of the harmonics and does not evaluate against the standard as in Harmonic Measurement Mode. When the next measured data is retrieved, the previous measured data is updated and does not remain.

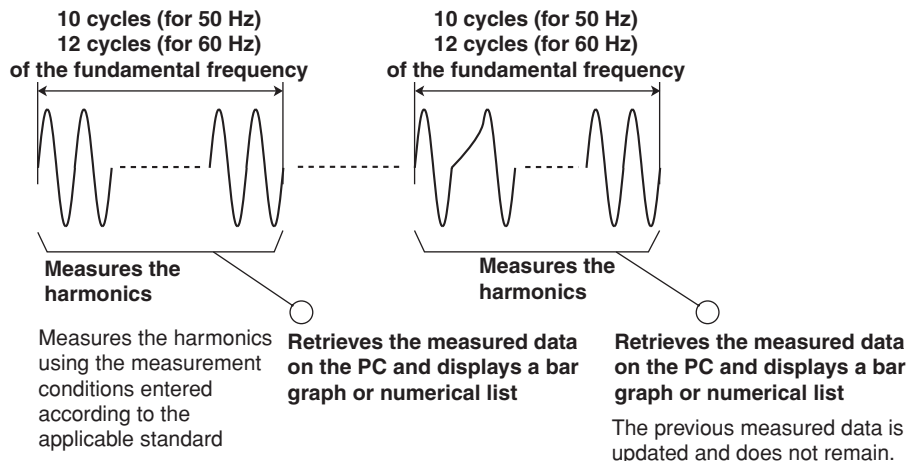

Waveform Monitor Mode

This mode can be selected only when in On-Line mode. The measured waveform can be monitored while making harmonic measurements on the WT. This mode is used to monitor the conditions of the waveform and does not evaluate against the standard as in Harmonic Measurement Mode. When the next waveform data is retrieved, the previous waveform data is updated and does not remain.

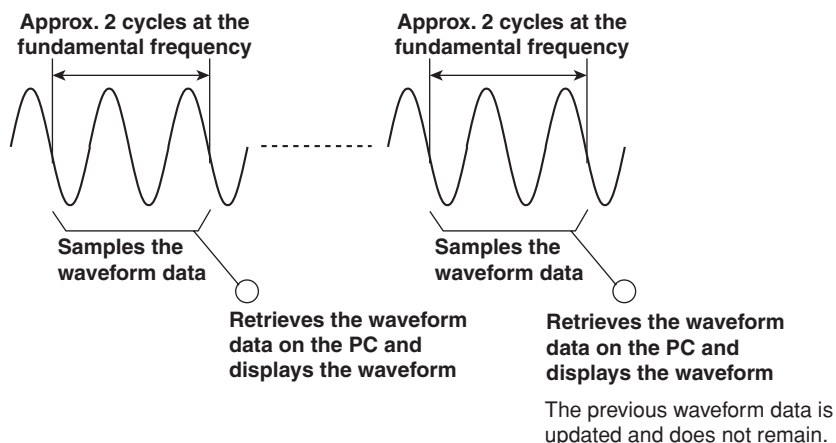

Setting the Standard and Measurement Environment

Sets the classification of the equipment under test (EUT) as defined in IEC 61000-3-2 Edition 2.2 or JIS and evaluation conditions within each class.

Setting the Measurement Time

The measurement time is the time between the start of the measurement to the end of the measurement. The time for measuring harmonics is set in units of 1 s in advance. The harmonics can be measured continuously for the specified time. The measurement time can be changed when equipment that emits harmonics that fluctuate over time is measured or when confirming that the emitted harmonics do not change even when the equipment is operated over extended time.

Setting the Title/Comment of Reports

A title or a comment of a report can be entered and saved or printed along with the harmonic measurement data. When printing, you can select whether to use color or black and white.

Starting/Stopping Measurements

Harmonic measurement on the WT can be started from your PC when in On-Line mode. The measurement cannot be started when in Off-Line mode.

When in Harmonic Measurement Mode

When harmonic measurement on the WT is started from the PC, the harmonics data measured on the WT is retrieved and stored on the PC. The next data is retrieved and stored as next data. All the data retrieved within the measurement time are stored. When the specified measurement time elapses, the measurement automatically stops as well as the data retrieval. You can also abort the measurement and data retrieval from the PC before the specified measurement time elapses.

When in Harmonic Monitor or Waveform Monitor Mode

When harmonic measurement on the WT is started from the PC, the harmonics data or waveform data measured on the WT is retrieved and stored on the PC. When the next data is retrieved, the previous data is updated and does not remain. These modes are used to monitor the conditions of the harmonics and waveforms and do not evaluate against the standard as in Harmonic Measurement Mode. To stop the measurement and data retrieval in these modes, press the Stop button.

Displaying the Evaluation Results and Measured Data/Waveform Data

The result of the evaluation as to whether the harmonic current data up to order 40 is within the limits of IEC 61000-3-2 Edition 2.2 or JIS and the corresponding measured data can be displayed. Various displays below are possible only when in Harmonic Measurement mode.

Display of the Evaluation Result within the Entire Measurement Time

Evaluation can be made as to whether all of the harmonic measurement data in the measurement time are within the limits according to the settings specified in "Setting the Standard and Measurement Environment" (as described earlier), and the results can be displayed collectively.

Bar Graph Display of Harmonic Current/Voltage

Bar graphs of the harmonic measurement data and the standard limits can be displayed for each order. Moreover, the evaluation as to whether harmonic current data is within the limits can be displayed using different colors. The harmonic current data to be evaluated is the mean value, the maximum value, and instantaneous values (one set of harmonic measurement data) of the measured data within the measured time. Both harmonic current and voltage can be displayed for each input element of the WT.

List Display of Harmonic Current/Voltage

A list of the harmonic measurement data and the standard limits can be displayed for each order. Moreover, the evaluation as to whether harmonic current data is within the limits can be displayed using different colors. The harmonic current data to be evaluated is the mean value, the maximum value, and instantaneous values (individual measurement data) of the measured data within the measured time. Both harmonic current and voltage can be displayed for each input element of the WT.

Fluctuation Graph Display of Harmonic Current

Graphs of the harmonic current fluctuation over time can be displayed for each order. The lists can be displayed for each input element of the WT.

Waveform Display of Voltage/Current

The waveform immediately after the end of the measurement can be displayed. Approximately 2 cycles of waveform is displayed. You can place the cursor on the current waveform and read the phase difference (phase angle) from the first zero-crossing point of the voltage waveform and the current value of the phase. The list can be displayed for each input element of the WT.

Fluctuation Graph Display of Voltage/Current/Active Power

Graphs of the fluctuation of the rms value of the voltage and current as well as the active power that is determined from the measured fundamental frequency and all harmonics can be displayed. The list can be displayed for each input element of the WT.

Bar Graph Display of the Phase Angle of the Harmonic Current

Bar graphs of the phase angle of the harmonic current with respect to the fundamental signal for each order can be displayed. The list can be displayed for each input element of the WT.

List Display of the Phase Angle of the Harmonic Current

A list of the phase angle of the harmonic current with respect to the fundamental signal for each order can be displayed. The list can be displayed for each input element of the WT.

Saving and Loading Setup Information, Measured Data, and Waveform Data

Saving and Loading Setup Information

Setup information such as the measurement mode, standard and measurement environment settings, measurement time, display format of bar graph and numerical list, title/comment of reports (one-page reports containing the bar graph/numerical list of the measured data and evaluation results) specified by the software can be saved. The setup information saved to a file can also be loaded.

Saving and Loading Measured Data/Waveform Data

The harmonic measurement data or waveform data retrieved from the WT in harmonic measurement mode into the PC using the software can be saved to a file. In this case, the harmonic measurement conditions of the WT specified using the software and the same data as the setup information described above are also saved. The harmonic measurement data, waveform data, harmonic measurement conditions, and setup information saved to a file can also be loaded.

Saving the Measured Data or Waveform Data in CSV Format

The harmonic measurement data or waveform data retrieved from the WT into the PC using the software can be saved to a file in CSV format. The software cannot load the data saved to a CSV file. Software applications installed on the PC that support files in CSV format can open the data.

Saving and Printing Screen Images and Reports

Screen images and reports can be saved to files in BMP format or printed.

- The active window among the displayed graph and list windows can be saved in BMP format or printed.
- A list or bar graph of the harmonic measurement data can be saved in BMP format or printed as a report. A title or comment can be attached to a report (see "Setting the Title/Comment of Reports" on page 1-3).

Repeatability of Measured Data

The maximum value and mean value in the harmonics measurement data saved to files can be compared, and the difference in the measured data can be displayed on a bar graph or numerical list for each order. This function can be used to evaluate whether the difference between data measured under the same measurement conditions when harmonics are measured using the same product or same product model is within 5% as defined in the standard (confirmation of repeatability).

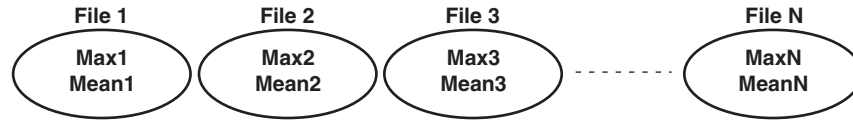

Comparison Using Maximum Values

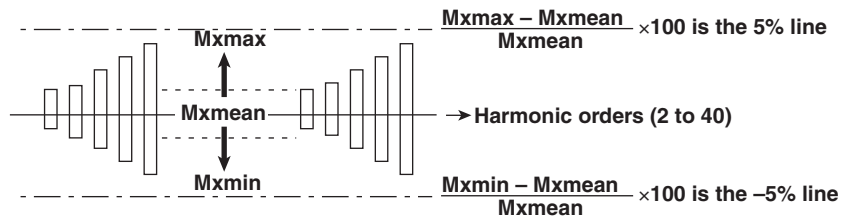

$Mxmean = (Max1 + Max2 + Max3 + \dots + MaxN)/N$

(Mxmean: The value derived by summing the maximum values of each file (Max1, Max2, Max3, ... MaxN) and dividing by the number of summed values (N). The value can be determined for each order.)

$Mxmax = [Max1, Max2, Max3, \dots, MaxN]_{max}$

(Mxmax: The maximum value among the maximum values of each file. The value can be determined for each order.)

$Mxmin = [Max1, Max2, Max3, \dots, MaxN]_{min}$

(Mxmin: The minimum value among the maximum values of each file. The value can be determined for each order.)

Comparison Using Mean Values

Comparison using mean values is obtained by replacing Mxmean, Mxmax, and Mxmin with Mnmean, Mnmax, and Mnmin, respectively in the figure of the comparison using maximum values.

$Mnmean = (Mean1 + Mean2 + Mean3 + \dots + MeanN)/N$

(Mnmean: The value derived by summing the mean values of each file (Mean1, Mean2, Mean3, ... MeanN) and dividing by the number of summed values (N). The value can be determined for each order.)

$Mnmax = [Mean1, Mean2, Mean3, \dots, MeanN]_{max}$

(Mnmax: The maximum value among the mean values of each file. The value can be determined for each order.)

$Mnmin = [Mean1, Mean2, Mean3, \dots, MeanN]_{min}$

(Mnmin: The minimum value among the mean values of each file. The value can be determined for each order.)

1.2 System Requirements

PC

CPU

Pentium III 1 GHz or equivalent or faster

Memory

256 MB or more

HDD

Free space of at least 2 GB.

Operating System

Windows 98, Windows Me, Windows 2000 Professional, Windows XP Home Edition, or Windows XP Professional.

Communication card

GP-IB

PCI-GPIB/PCI-GPIB+/PCMCIA-GPIB/PCMCIA-GPIB+ by National Instruments with NI-488.2M driver version 1.60 or later.

Ethernet

A 10BASE-T or 100BASE-TX Ethernet port.

CRT, Printer, and Mouse

Those compatible with Windows 98, Windows Me, Windows 2000 Professional, Windows XP Home Edition, or Windows XP Professional.

WT3000

WT3000 firmware version 3.01 or higher with the following functions.

- Advanced computation function (option)
- GP-IB interface (standard) or Ethernet interface (option)

1.3 Applicable Standards

The applicable standards of this software application are as follows:

- IEC 61000-3-2(Electromagnetic compatibility (EMC) - Part 3-2: Limits - Limits for harmonic current emissions (equipment input current ≤ 16 A per phase)) Edition 2.2
- EN61000-3-2 (2000)
- IEC61000-4-7 Edition 2
- JIS C61000-3-2 (2005) JIS: Japanese Industrial Standard

This section gives an overview of the standards. For further details, see the actual text of the applicable standard.

Scope and Classification

The limits for harmonic current emissions (IEC61000-3-2 or JIS) are applicable to electrical and electronic equipment having an input current of up to 16 A (up to 20 A for JIS) per phase and connected to public low-voltage distribution systems. Classification is made depending on the type of equipment. IEC 61000-3-2 Edition 2.2 does not define the limits for some types of equipment. For details, see the applicable standard.

-Electrical and electronic equipment having an input current up to 16 A per phase-

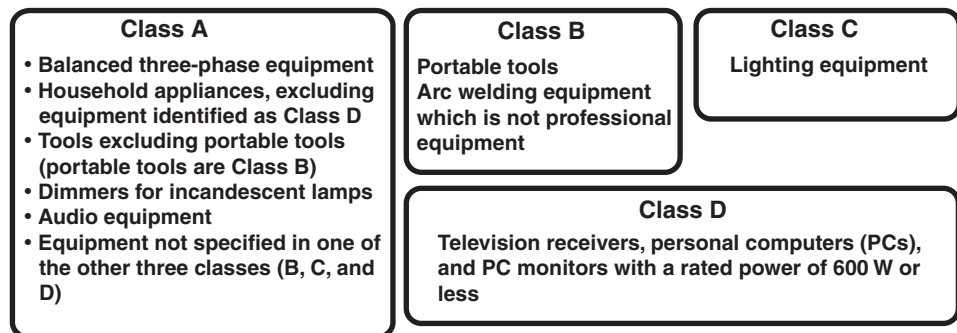

Limits

The limits are specified for each class. IEC 61000-3-2 assumes a phase voltage of 220 V, 230 V, and 240 V for specifying the limits. For equipment of differing rated voltage, conversion may be necessary. For the conversion equation, see "Conversion of Limits" (page 1-10). The limits of JIS C-61000-3-2(2005) are the same as those of IEC61000-3-2. However, limits indicated on the next page apply to air conditioners of class A whose active power exceeds 600 W.

Limits for Class A Equipment

Harmonic order n	Maximum permissible harmonic current [A]
Odd harmonics	
3	2.30
5	1.14
7	0.77
9	0.40
11	0.33
13	0.21
$15 \leq n \leq 39$	$0.15 \times (15/n)$
Even harmonics	
2	1.08
4	0.43
6	0.30
$8 \leq n \leq 40$	$0.23 \times (8/n)$

In JIS C61000-3-2(2005), the limits below apply to air conditioners whose active power exceeds 600 W.

Harmonic order n	Maximum permissible harmonic current [A]
Odd harmonics	
3	2.30+0.00283(W-600)
5	1.14+0.00070(W-600)
7	0.77+0.00083(W-600)
9	0.40+0.00033(W-600)
11	0.33+0.00025(W-600)
13	0.21+0.00022(W-600)
15≤n≤39	(0.15+0.00020(W-600))×(15/n)
Even harmonics	
2	1.08+0.00033(W-600)
4	0.43+0.00017(W-600)
6	0.30+0.00012(W-600)
8≤n≤40	(0.23+0.00009(W-600))×(8/n)

Limits for Class B Equipment

Limits for Class A equipment×1.5

Limits for Class C Equipment

Classification is made according to the active power of the equipment shown below. For single-phase equipment, the classification is made using the active power of the single-phase power. For multi-phase equipment, the classification is made using the sum of the active powers all phases (three phases if three-phase).

- **Equipment with active input power exceeding 25 W**

Harmonic order n	Maximum permissible harmonic current expressed as a percentage of the input current at the fundamental frequency [%]
2	2
3	30×λ*
5	10
7	7
9	5
11≤n≤39 (Odd harmonics only)	3

* λ is the power factor (circuit power factor).

For the fundamental current and power factor, use the measured values under maximum load conditions of the equipment.

- **Equipment with active input power less than or equal to 25 W**

Shall meet one of the two conditions below.

1. Does not exceed the power ratio limits of Class D.
2. The third and fifth harmonics shall not exceed the limits given in the table below. Moreover, the relationship of the fundamental voltage waveform and the input current waveform shall be as shown in the figure below.

Harmonic order n	Maximum permissible harmonic current expressed as a percentage of the input current at the fundamental frequency [%]
3	86
5	61

1.3 Applicable Standards

The relationship of the fundamental supply voltage waveform and the input current waveform is as follows, where the zero crossing of the fundamental supply voltage is assumed to be at 0° (degrees).

- Beginning of the current flow: Before or at 60°
- Last current peak: Before or at 65°
- End of the current flow: 90° or after

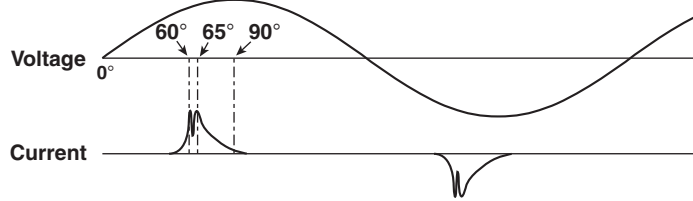

Limits for Class D Equipment

Shall meet the maximum permissible harmonic current (power ratio limit) per watt and the maximum permissible current given in the next table. The concept of power (active power) of single- or multi-phase equipment is the same as Class C.

Harmonic order n	Maximum permissible harmonic current per watt [mA/W] (Power ratio limit)	Maximum permissible harmonic current (Odd harmonics only) [A]
3	3.4	2.30
5	1.9	1.14
7	1.0	0.77
9	0.5	0.43
11	0.35	0.33
13 ≤ n ≤ 39 (Odd harmonics only)	3.85/n	Same as class A.

Conversion of Limits

IEC 61000-3-2 assumes a phase voltage of 220 V, 230 V, and 240 V for specifying the limits. For equipment of differing rated voltage, conversion may be necessary. Convert the limits of all the classes using the following equations and apply them. However, conversion to a phase voltage of 220 V or 240 V is not necessary.

Phase voltage

$$\text{Converted limit} = \text{Limit of each class} \times \frac{230}{\text{Rated voltage of the equipment}}$$

Line voltage of three-phase

$$\text{Converted limit} = \text{Limit of each class} \times \frac{400}{\text{Rated voltage of the equipment}}$$

Specifications of Supply Source, Measurement Equipment, Test Conditions, and Application Method of Limits.

This section lists only the items. For detailed specifications, see the applicable standard.

Power Supply

- Supply voltage and frequency range.
- Permissible range of harmonics contained in the supply voltage.
- Voltage peak value and phase offset between the waveform zero crossing and the peak value.
- Internal impedance of the supply source.
- Angle between the fundamental voltage on each pair of phases in the case of a three-phase source.

Measurement Equipment

- Error of the measurement equipment.
- Input impedance of the measurement equipment.
- Time constant of the internal processing when measuring harmonics.

Test Conditions

- Test conditions for television/audio equipment and lighting equipment.
- Test conditions for general equipment not specified in the applicable standard. For example, performing tests by setting the equipment to a condition that produces the maximum total harmonic current (THC).
- Specification of the repeatability of the measurement results.
- Specification of the observation time (measurement time) to achieve the repeatability of the measurement results.

Application Method of Limits

- Derivation of the fundamental current and power factor (circuit power factor) of class C equipment.
- Derivation of the power (active power) used by class D equipment
- Specifications when comparing the harmonic current limits and measured values for each order.
 - Compare the specified limit and the mean value of the harmonic current within the measurement time and evaluate.
 - Compare the value that is 1.5 times the specified limit and the maximum value of the harmonic current within the measurement time and evaluate.
- Relaxation of the specification
If the total partial odd harmonic currents (POHC) of order above and including 21 is less than the specified POHC limit, the average of the odd harmonic currents of order above and including 21 is permitted to be 1.5 times the specified limits.

Window Function of the WT3000 and WT2000/WT1600 (Measurement Period)

- The width of the window function (measurement period) for the measurements on the WT3000 is 200 ms (10 cycles at 50 Hz and 12 cycles at 60 Hz) as defined by IEC61000-4-7 Edition 2.
- The width of the window function (measurement period) for the measurements on the WT2000/WT1600 is 16 cycles as defined by IEC61000-4-7 (1991).

1.4 Flow of Operation (GP-IB)

To display and evaluate harmonic measurement data using this software, the WT Digital Power Meter and PC must be connected via the GP-IB interface, the software must be installed, WT measurement conditions must be set, and evaluation conditions of the applicable standard must be set. Follow the steps below.

Preparation Flow Chart

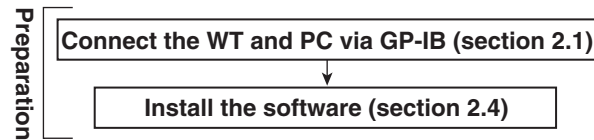

On-Line Mode Flow Chart

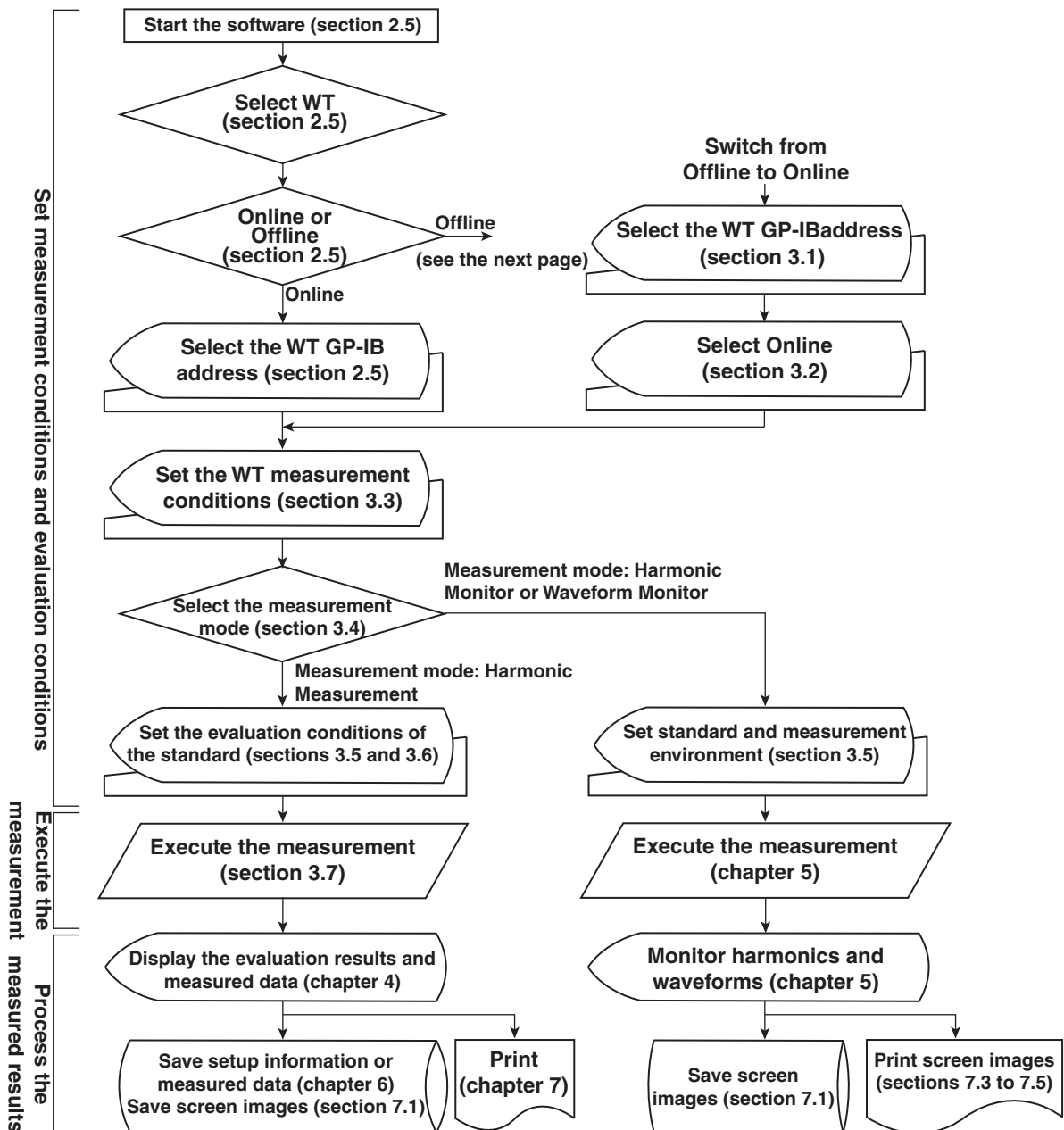

Off-Line Mode Flow Chart

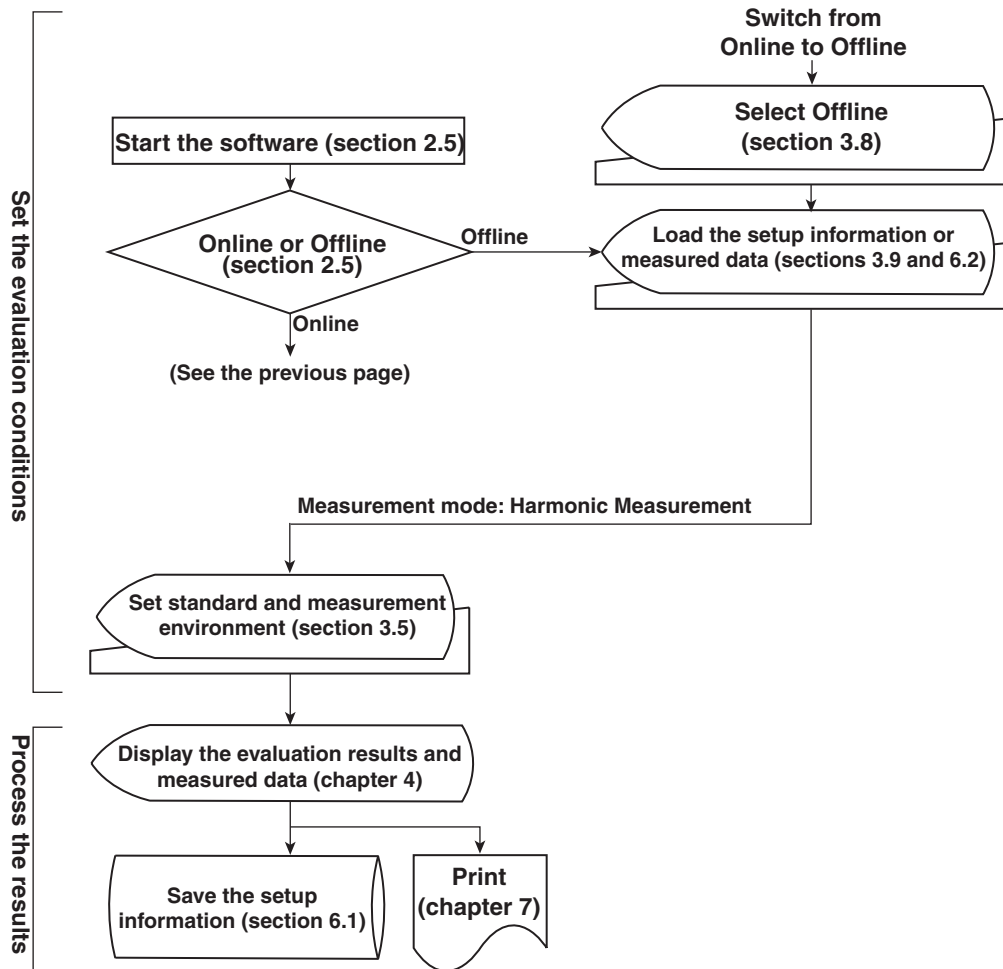

1.5 Flow of Operation (Ethernet : WT3000 Option)

To display and evaluate harmonic measurement data using this software, the WT and PC must be connected via the Ethernet interface, the software must be installed, WT measurement conditions must be set, and evaluation conditions of the applicable standard must be set. Follow the steps below.

Preparation Flow Chart

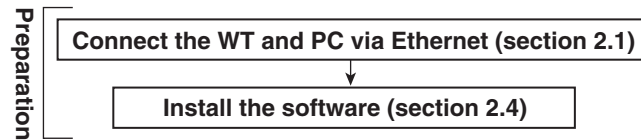

On-Line Mode Flow Chart

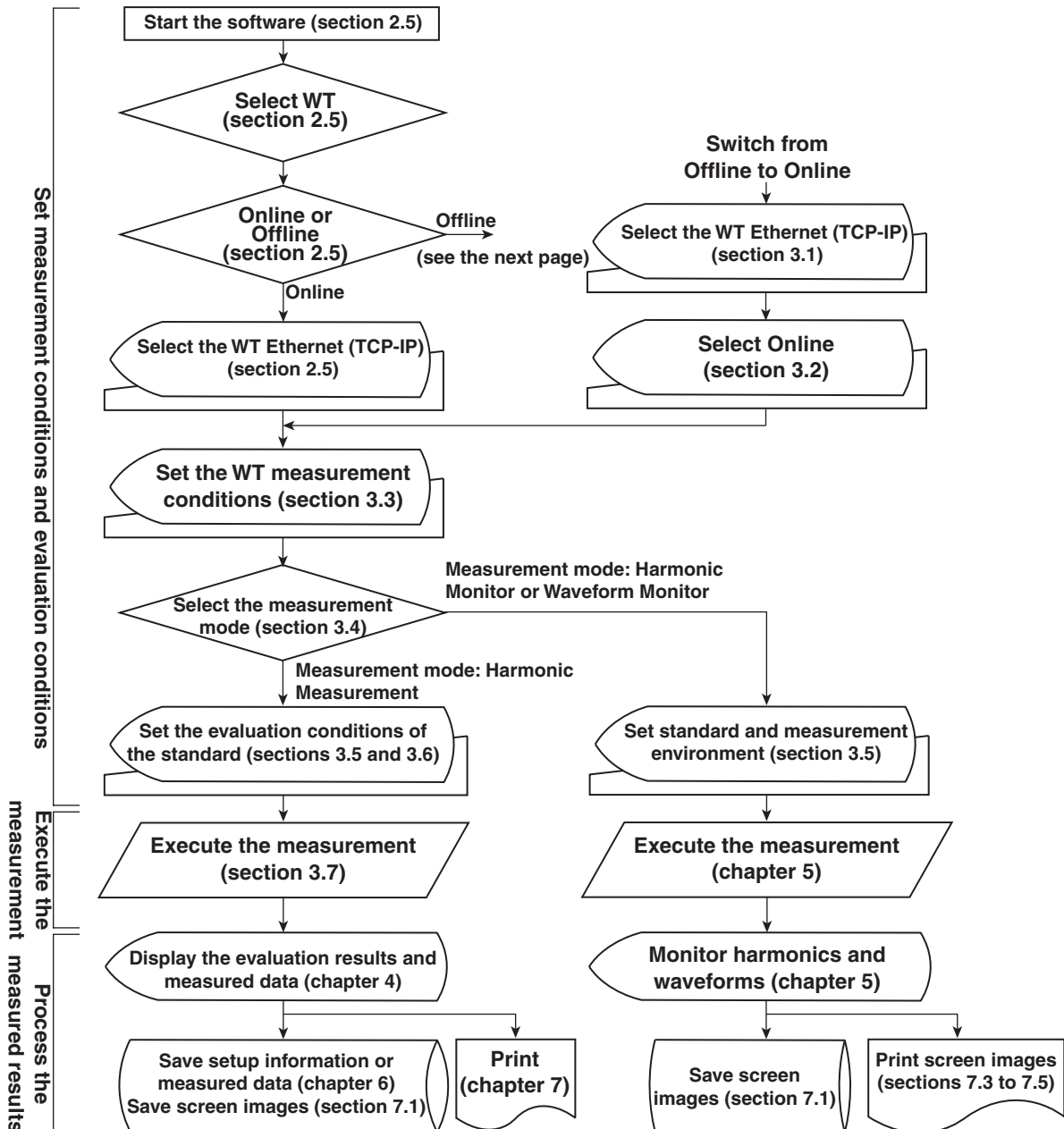

Off-Line Mode Flow Chart

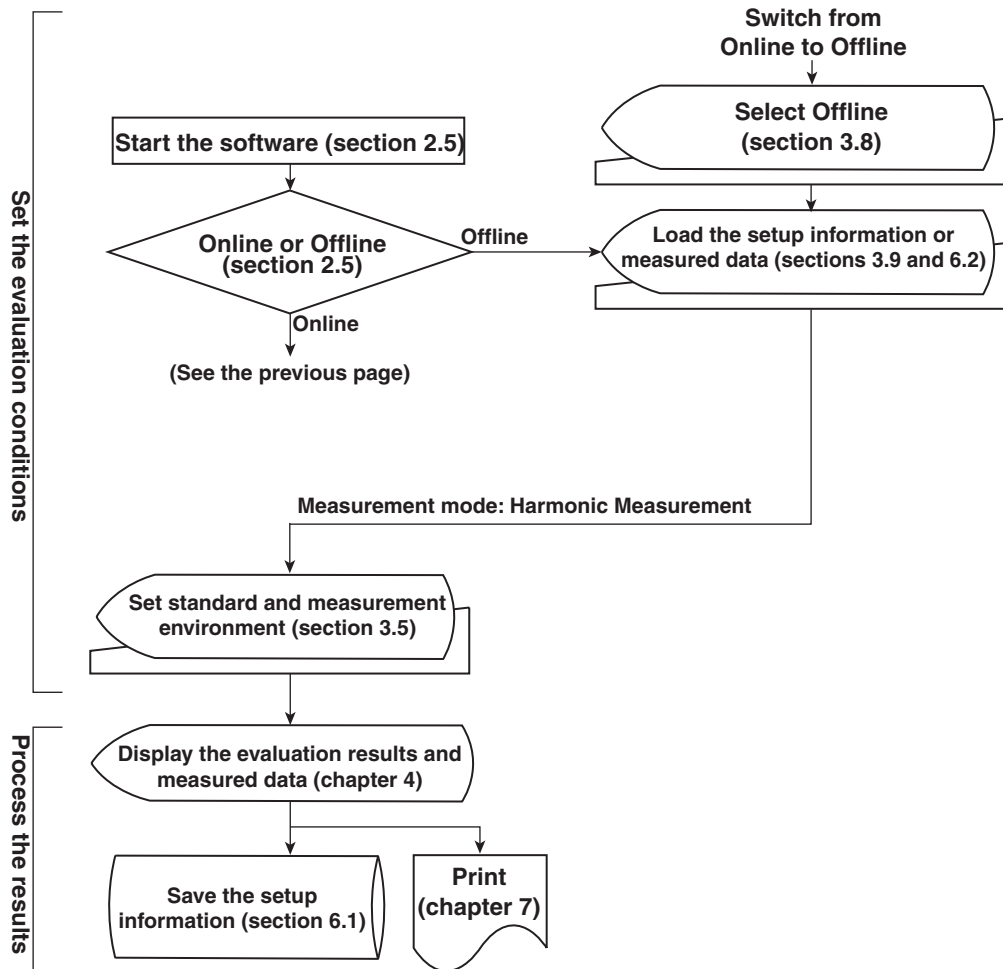

1.6 Terminology Related to Harmonics

Harmonics refer to sine waves whose frequency is an integer multiple of the fundamental wave (normally sine waves of commercial frequency 50-Hz or 60-Hz) excluding the fundamental frequency.

Fundamental Wave (Fundamental Component)

The sine wave with the longest period among the different sine waves derived from the periodic complex wave. Or the sine wave that has the fundamental frequency within the components of the complex wave.

Fundamental Frequency

The frequency corresponding to the longest period in the periodic complex wave. The frequency of the fundamental wave.

Distorted Wave

A wave that differs from the fundamental wave.

Higher Harmonic

A sine wave with frequency that is an integer multiple (twice or greater) of the fundamental frequency.

Harmonic Component

Waveform component with frequency that is an integer multiple (twice or greater) of the fundamental frequency.

Harmonic Order

Integer ratio of the harmonic frequency with respect to the fundamental frequency. IEC defines the maximum harmonic order that is measured to be 40.

PLL Source

When measuring harmonics, the fundamental period (period of the fundamental signal) must be determined in order to analyze the higher orders. The PLL (Phase Locked Loop) source is the signal that is used to determine the fundamental period.

THC (Total Harmonic Component)

Sum (rms value) of harmonic currents of orders 2 to 40.

$$\sqrt{\sum_{k=2}^{40} I(k)^2}$$

I(k): rms current of each order
k: harmonic order

THD (Total Harmonic Distortion)

The ratio of the rms value of all harmonics of orders 2 to 40 and the rms value of the fundamental wave.

• V THD

$$\frac{\sqrt{\sum_{k=2}^{40} U(k)^2}}{U(1)} \times 100$$

• A THD

$$\frac{\sqrt{\sum_{k=2}^{40} I(k)^2}}{I(1)} \times 100$$

• P THD

$$\left| \frac{\sum_{k=2}^{40} P(k)}{P(1)} \right| \times 100$$

U(k): rms voltage of each order, U(1): rms voltage of the fundamental signal
I(k): rms current of each order, I(1): rms current of the fundamental signal
P(k): active power of each order, P(1): active power of the fundamental signal
k: harmonic order

Interharmonics

If the input signal is 50 Hz in IEC harmonic measurement, Fourier transform is taken on 10 periods of the input signal to derive frequency components of 5-Hz resolution. Thus, the section between each harmonic order is divided into 10 frequency components. The components between each harmonic order are called interharmonics.

When the fundamental signal is 50 Hz

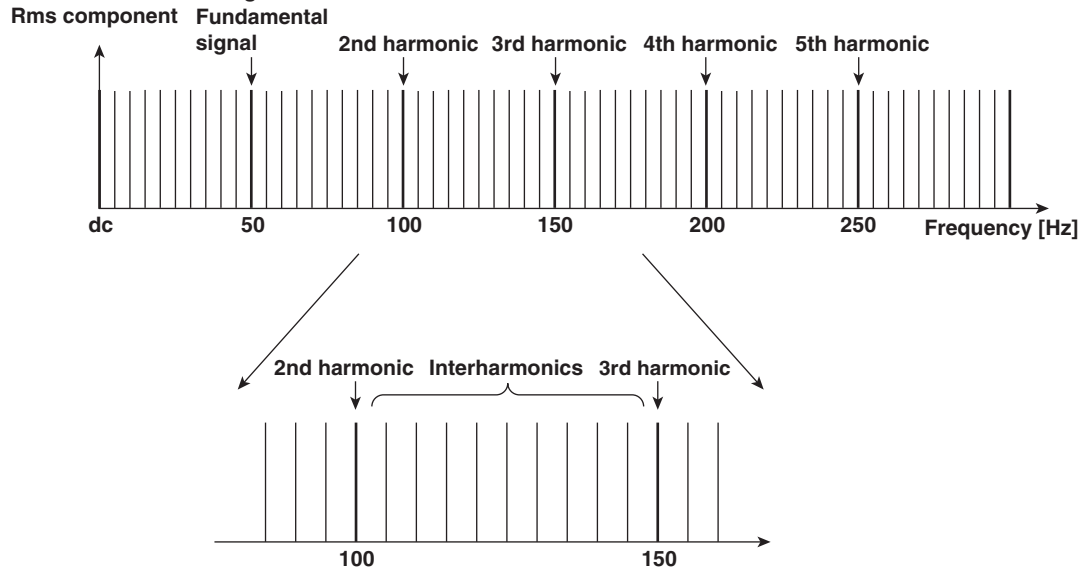

If the input signal is 60 Hz, 12 periods of the input waveform are divided into frequency components of 5-Hz resolution. Thus, the section between each harmonic order is divided into 12 frequency components.

When the fundamental signal is 60 Hz

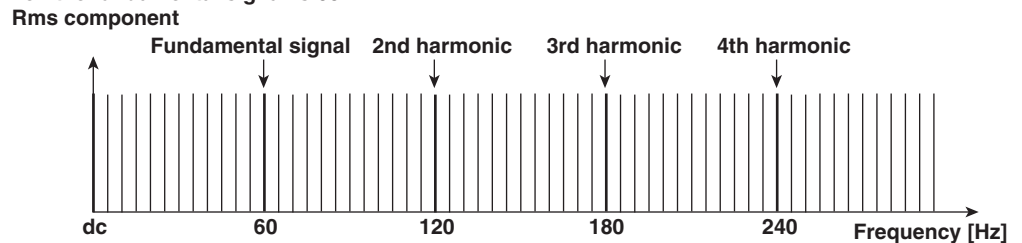

1.6 Terminology Related to Harmonics

Harmonic Group

The combined value of a harmonic and its adjacent interharmonics (rms value). The computing method to combine the harmonic and its two adjacent interharmonics is not simple addition, but the square root of the sum of the square of each component. A half of the amplitude is included for the interharmonic that is in the middle of two harmonics.

When the fundamental signal is 50 Hz

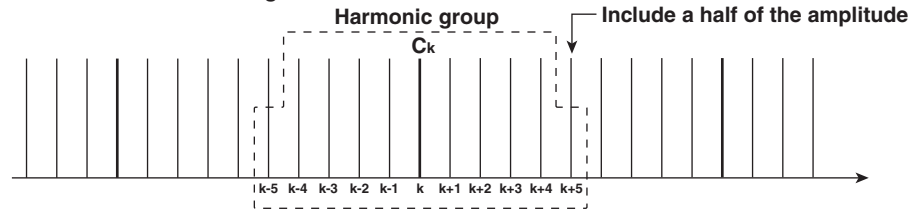

When the fundamental signal is 60 Hz

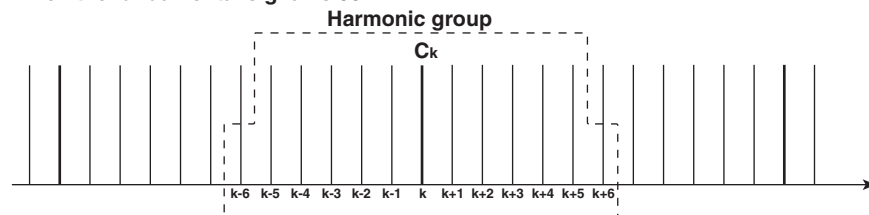

$$G_{g,n} = \sqrt{\frac{C_{k-5}^2}{2} + \sum_{i=-4}^4 C_{k+i}^2 + \frac{C_{k+5}^2}{2}} \quad (\text{for 50 Hz})$$

$$G_{g,n} = \sqrt{\frac{C_{k-6}^2}{2} + \sum_{i=-5}^5 C_{k+i}^2 + \frac{C_{k+6}^2}{2}} \quad (\text{for 60 Hz})$$

C_k : frequency component for every 5 kHz

Harmonic Subgroup

The combined value (rms value) of a harmonic and its two adjacent interharmonics. The computing method to combine the components is the average of the sum of the squares as with the harmonic group.

When the fundamental signal is 50 Hz

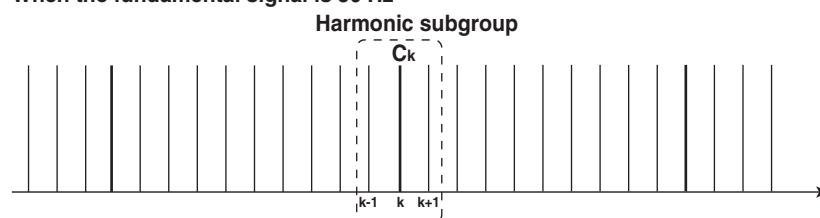

$$G_{sg,n} = \sqrt{\sum_{i=-1}^1 C_{k+i}^2}$$

C_k : frequency component for every 5 kHz

THDG (Group Total Harmonic Distortion)

The ratio of the sum of all harmonic groups of orders 2 to 40 with respect to the group related to the fundamental wave.

• V THDG

$$\frac{\sqrt{\sum_{k=2}^{40} U_g(k)^2}}{U_g(1)} \times 100$$

• A THDG

$$\frac{\sqrt{\sum_{k=2}^{40} I_g(k)^2}}{I_g(1)} \times 100$$

$U_g(k)$, $I_g(k)$: rms value of the harmonic group of each order
 k : harmonic order

THDS (Subgroup Total Harmonic Distortion)

The ratio of the sum of all harmonic sub groups of orders 2 to 40 with respect to the sub group related to the fundamental wave.

• **V THDS**

$$\frac{\sqrt{\sum_{k=2}^{40} U_{sg}(k)^2}}{U_{sg}(1)} \times 100$$

• **A THDS**

$$\frac{\sqrt{\sum_{k=2}^{40} I_{sg}(k)^2}}{I_{sg}(1)} \times 100$$

U_{sg}(k), I_{sg}(k): rms value of the harmonic subgroup of each order
k: harmonic order

Interharmonic Group

The combined value (rms value) of all interharmonic components between two consecutive harmonic frequencies.

When the fundamental signal is 50 Hz

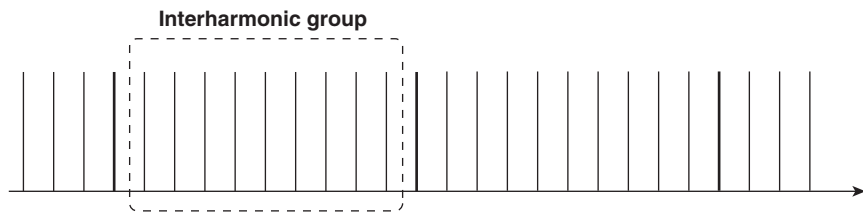

When the fundamental signal is 60 Hz

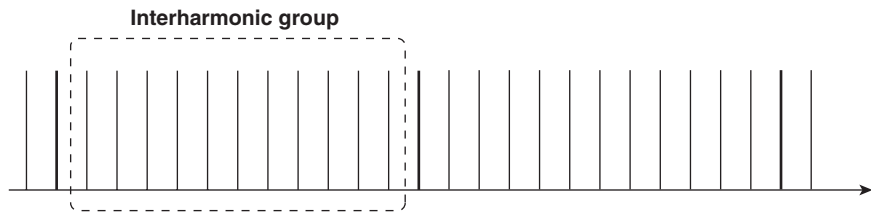

Interharmonic Center Subgroup

The combined value (rms value) of all interharmonic components between two consecutive harmonic frequencies excluding the frequency components adjacent to the harmonic frequencies.

When the fundamental signal is 50 Hz

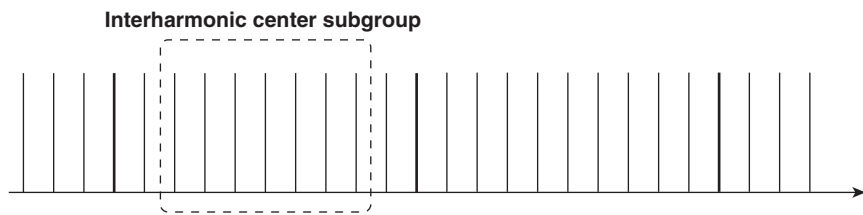

When the fundamental signal is 60 Hz

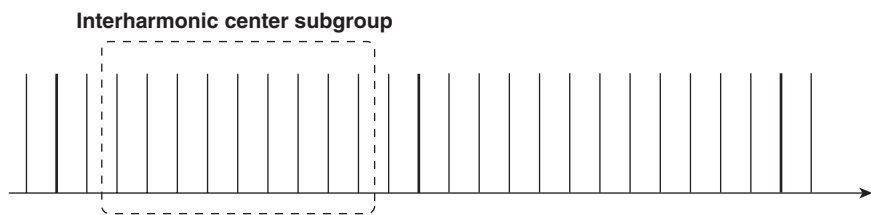

POHC: The combined value of all odd harmonic currents greater than or equal to order 21

$$\sqrt{\sum_{k=21, 23}^{39} I(k)^2}$$

I(k): rms current of odd harmonics above and including order 21
 k: harmonic order, odd value above and including 21

PoHC Maximum: The maximum value of the combined value of all odd harmonic currents greater than or equal to order 21

The POHC maximum derived from individual measured data points within the measurement time. If this value is less than the POHC Limit below, the relaxation condition (see page 4-3) is applied.

POHC Limit

$$\sqrt{\sum_{k=21, 23}^{39} I_L(k)^2}$$

I_L(k): limits of odd harmonics above and including 21 as specified by the applicable standard
 k: harmonic order, odd value above and including 21

Crest Factor

The crest factor is defined as the ratio of the peak value of the waveform to the rms value.

$$\text{Crest factor (CF)} = \frac{\text{Peak value}}{\text{RMS value}}$$

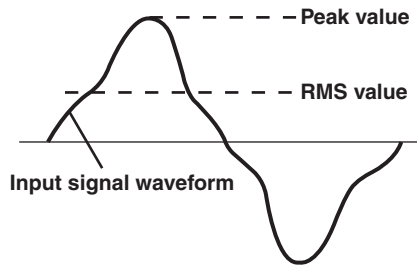

The crest factor on the WT is determined by the maximum peak value that can be applied for rated input in terms of a multiplication factor.

$$\text{Crest factor (CF)} = \frac{\text{Peak value that can be input}}{\text{Measurement range}}$$

You can select a crest factor of 3 or 6 on the WT3000. For details on the measurement accuracy and crest factor of the IEC standard, see chapter 10, "Specifications." Highly accurate measurements can be performed by setting the crest factor to 3.

2.1 Connecting the WT3000 and the PC

CAUTION

When connecting or disconnecting communication cables, make sure to turn OFF the PC and the WT. Otherwise, erroneous operation or damage to the internal circuitry may result.

When Controlling the WT through the GP-IB

The GP-IB connector used on the WT is a 24-pin connector that conforms to the IEEE St'd 488-1978. Use a GP-IB cable that conforms to this standard. Connect the cable to the GP-IB connector on the rear panel of the WT. For details on the connection procedure and the specifications of the GP-IB interface, see the *WT3000 Communication Interface User's Manual IM760301-17E* on the CD-ROM. Use an appropriate connector for your PC to connect the other end of the GP-IB cable.

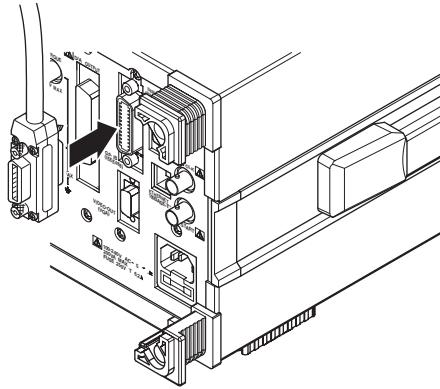

When Controlling the WT through the Ethernet Interface

Connect the WT and your PC through a hub using straight UTP (Unshielded Twisted-Pair) or STP (Shielded Twisted-Pair) cables. Connect the cable to the ETHERNET port on the rear panel of the WT. Use hubs, cables, and Ethernet NIC that are appropriate for the data rate. For details on the connection procedure and the specifications of the Ethernet interface, see the *Expansion Function User's Manual IM760301-51E* of the WT3000 and the *WT3000 Communication Interface User's Manual IM760301-17E* on the CD-ROM.

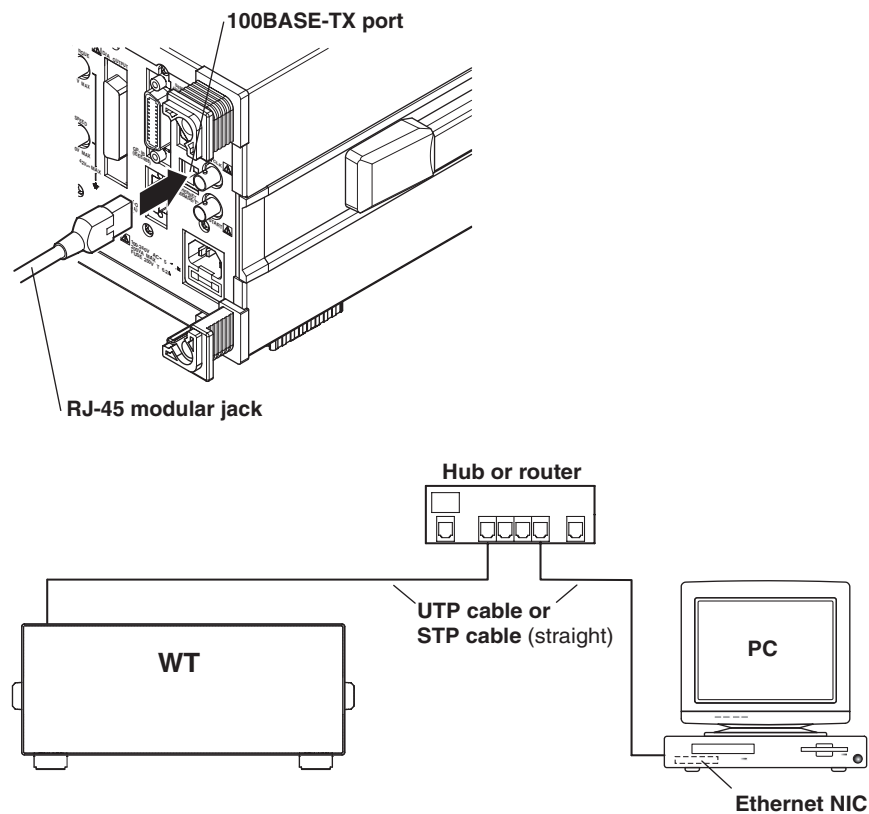

Note

- Use UTP (Unshielded Twisted-Pair) or STP (Shielded Twisted-Pair) cables of category 5 or better when connecting to a 100BASE-TX network.
 - Do not directly connect the WT to the PC without using a hub. Operations are not guaranteed for communications using direct connection.
-

2.2 Setting the GP-IB Control

Procedure

1. Press **MISC** to display the Misc menu.
2. Press the **Remote Control** soft key to display the Remote Ctrl menu.
3. Press the **Device** soft key to select GP-IB.
Only the communication interface selected here is enabled. The WT does not accept commands that are transmitted to other unselected communication interfaces.
4. Press the **cursor keys** to set the address.

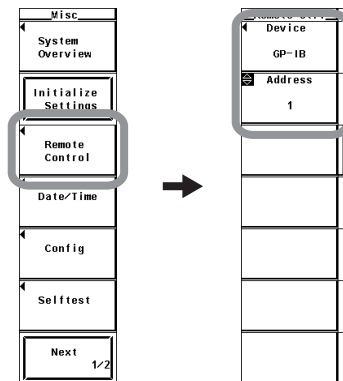

2.2 Setting the GP-IB Control

Explanation

To use the software in On-Line mode through the GP-IB interface, operate the WT to select GP-IB.

Setting the Address

Set the address of the WT within the following range.

0 to 30

Each device that can be connected via GP-IB has a unique address within the GP-IB system. This address is used to distinguish the device from others. Therefore, make sure that the WT address does not overlap with other devices when connecting the WT to the PC.

Note

- Do not change the address while the controller (PC) or other devices are using the GP-IB system.
 - When connecting the WT to a single PC and controlling the WT using this software, multiple communication interfaces cannot be used simultaneously.
 - Use a GP-IB card by National Instruments on the PC end. For details, see section 1.2.
 - The software may not operate correctly, if an adapter is inserted in the middle of the connection between the WT and the PC (for example, GP-IB-to-USB adapter). For details, contact your nearest YOKOGAWA dealer.
-

2.3 Setting the Ethernet Control

Procedure

Setting the Ethernet Interface

1. Press **MISC** to display the Misc menu.
2. Press the **Remote Control** soft key to display the Remote Ctrl menu.
3. Press the **Device** soft key to select Network.

Only the communication interface selected here is enabled. The WT does not accept commands that are transmitted to other unselected communication interfaces.

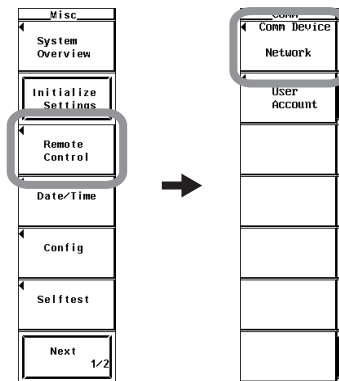

Setting the User Name and Password

4. Press the **User Account** soft key to display the User Account dialog box.
5. Press the **cursor keys** to select User Name..
6. Press **SET** to display the keyboard.
7. Use the **keyboard** on the WT to enter the user name.
For the keyboard operation of the WT, see the WT User's Manual.
8. Press the **cursor keys** to select Password.
9. Press **SET** to display the keyboard.
10. Use the **keyboard** on the WT to enter the password.
Enter the password twice for confirmation.
A password is not required if the login name is anonymous.
For the keyboard operation of the WT, see the WT User's Manual.

2.3 Setting the Ethernet Control

Setting the Timeout Value

11. Press the **cursor keys** to select Time Out.
12. Press **SET** to display the timeout time selection box.
13. Press the **cursor keys** to set the timeout value.
14. Press **SET** or **ESC** to close the box.

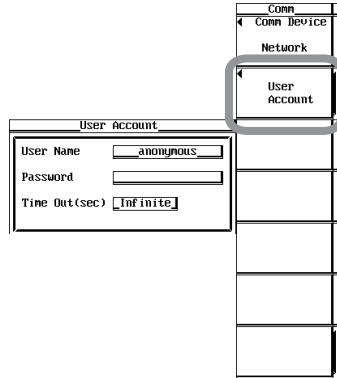

Setting TCP/IP

You must enter TCP/IP settings to control the WT from a PC through the network. For the setup procedure, see the *Expansion Function User's Manual IM760301-51E* of the WT3000.

Explanation

To use the software in On-Line mode through the network, operate the WT to select Network.

Setting the User Name

- Enter the user name to allow access to the WT.
- Enter up to 15 characters.
- The characters that can be used are 0-9, A-Z, %, _, () (parentheses), - (hyphen).
- If you specify anonymous, the WT can be accessed from the PC without a password.

Setting the Password

- Enter the password of the user name to allow access to the WT.
- Enter up to 15 characters.
- The characters that can be used are 0-9, A-Z, %, _, () (parentheses), - (hyphen).
- If you set the user name to anonymous, the WT can be accessed from the PC without a password.

Setting the Timeout Value

The WT closes the connection to the network if there is no access for a certain period of time (timeout value).

The available settings are 0 to 3600 s, or Infinite. The default value is Infinite.

Note

- To activate the settings, you must power cycle the WT.
 - When connecting the WT to a single PC and controlling the WT using this software, multiple communication interfaces cannot be used simultaneously.
 - The software may not operate correctly, if an adapter is inserted in the middle of the connection between the WT and the PC (for example, GP-IB-to-USB adapter). For details, contact your nearest YOKOGAWA dealer.
-

2.4 Installing the Software

Procedure

Have the CD-ROM containing the software ready. Exit all programs that are currently running before starting the installation. If an older version of the Harmonic Measurement Software is installed, uninstall it first.

The following procedures are for installing the software on Windows 2000 Professional. The screens shown in the figure may vary depending on the OS that is running on the PC.

1. Start Windows.
When using Windows 2000, Windows XP Home Edition, or Windows XP Professional, set the user name to Administrator when starting up.
2. Place the installation CD-ROM containing the software into the CD-ROM drive.
3. Double-click My Computer, then the CD-ROM icon.
4. Double-click **Setup.exe**. InstallShield Wizard starts.

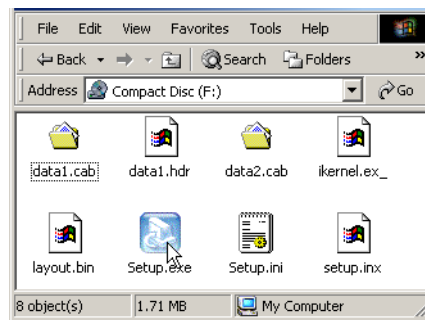

Startup window of the InstallShield Wizard.

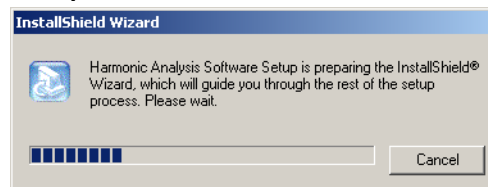

5. Click **Next**.

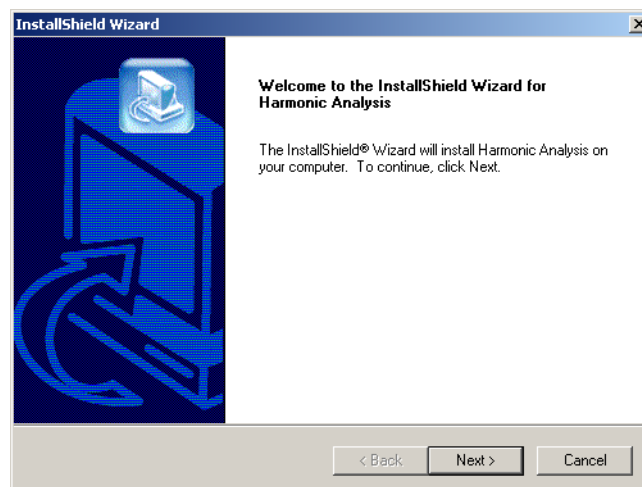

2.4 Installing the Software

6. If you accept the terms of with the license agreement, select **Yes**. If you do not, select **No**.

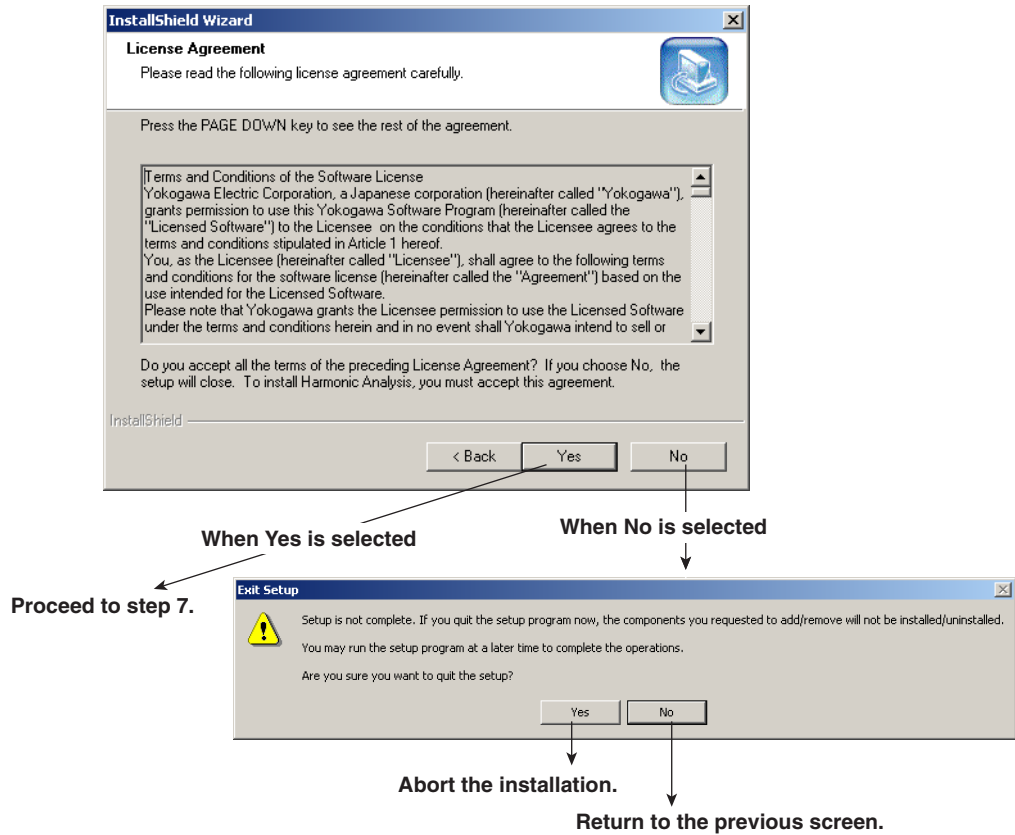

7. Select the installation destination, and click **Next**.
Click **Browse** to specify the installation destination. The default installation destination is set to "C:\Program Files\Yokogawa\Harmonic Analysis."

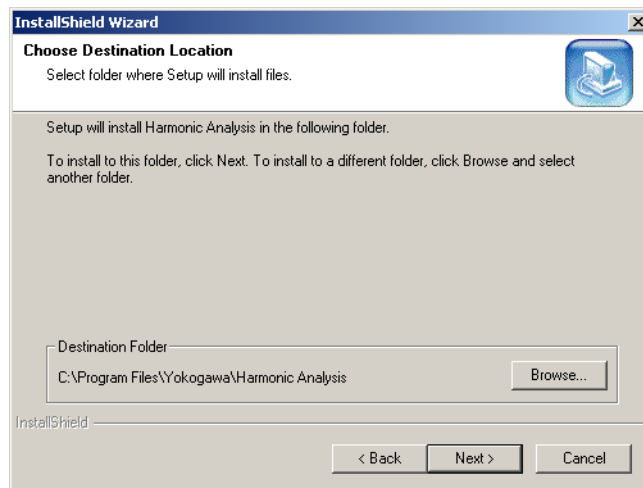

8. Select the program folder where the program icon is to be added and click **Next**. The installation starts.

The program icon (shortcut) of the software is added in the program menu of the Start menu. The destination is selected here. The default program folder is Yokogawa.

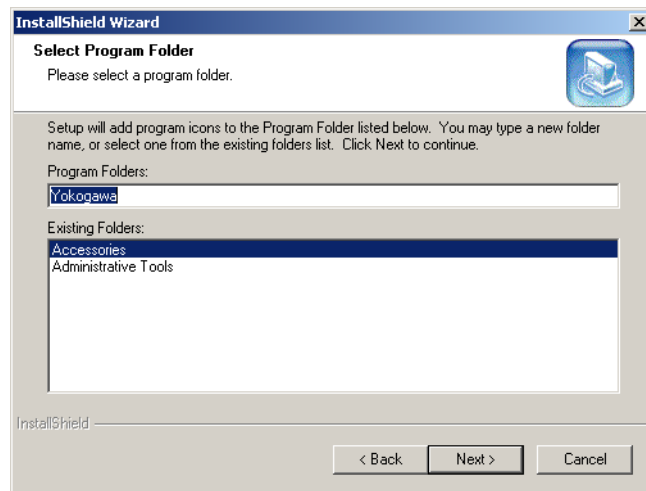

9. If the installation completes successfully, a message "Setup has finished installing" is displayed. Click **Finish**.

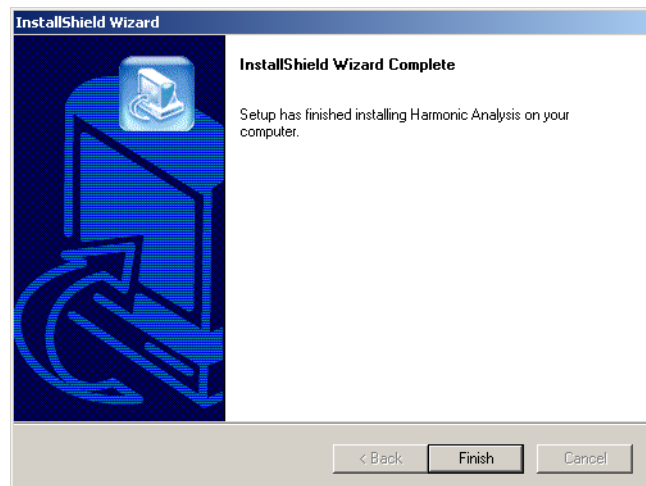

2.5 Starting and Exiting the Software

Procedure

Starting the Software

Starting the Software

1. From the **Start** menu, choose **Programs > Yokogawa > Harmonic Analysis > IEC61000_3_2**. The software starts.

The procedure above applies when the default software installation destination and program folder are used. If you changed the installation destination or program folder at installation, select the corresponding location.

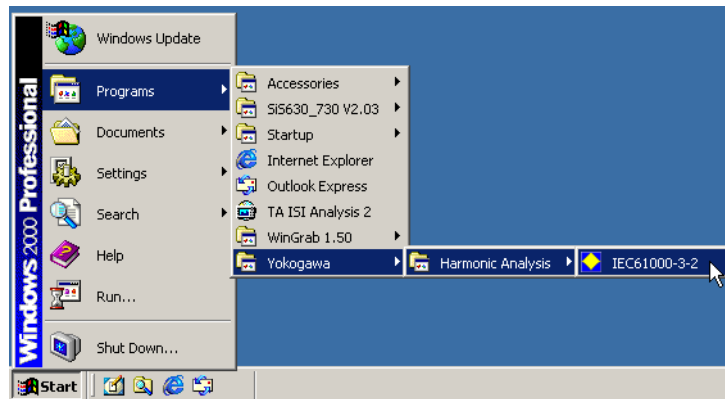

2. When you start the software, a dialog box appears for you to select the WT model.

Selecting the WT Model

3. Select WT3000.

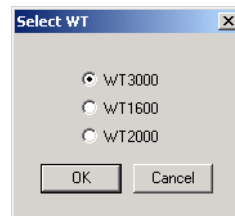

Selecting the Communication Mode

4. Select **Online** or **Offline**.

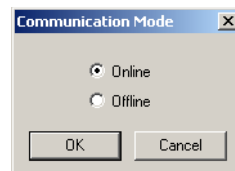

- If you selected Online, proceed to step 5.
- If you selected Offline, proceed to section 3.9.

Selecting the Crest Factor (CF)

5. Select **CF3** or **CF6**.

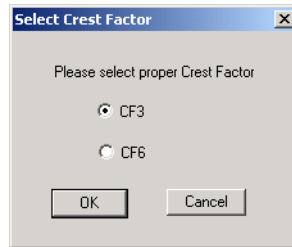
**Selecting the Communication Interface**

6. Select GPIB or Ethernet.



If you selected GP-IB, proceed to step 7.

If you selected Ethernet, proceed to step 8.

Selecting the Communication Address

7. In the Initialize Interface dialog box that is displayed, select the GP-IB address of the target WT.

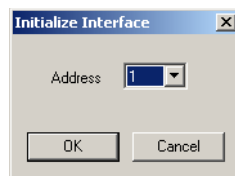
**Note**

GP-IB address 0 cannot be selected, because it is reserved for use by the PC.

2.5 Starting and Exiting the Software

Selecting the GP-IB address and clicking **OK** starts communications with the target WT. After automatically confirming that communication is possible, an acquisition data window appears. Setup and execution of measurements are now possible.

Acquisition Data Window

For a detailed description of the acquisition data window, see section 3.7.

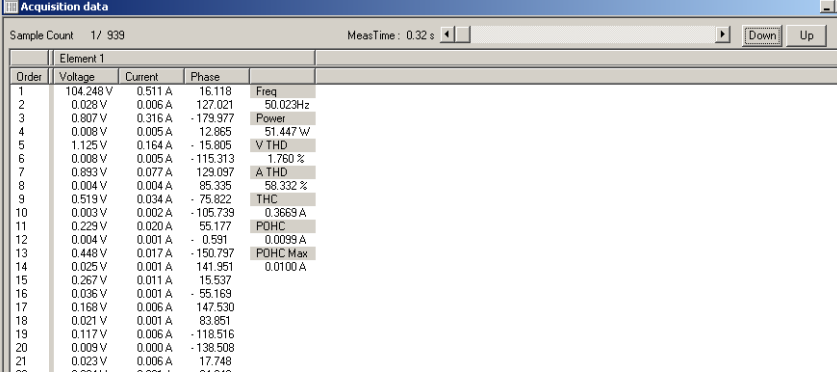

The screenshot shows a window titled "Acquisition data" with a table of measurement data. The table has columns for Order, Voltage, Current, Phase, and Freq. The data is as follows:

Order	Voltage	Current	Phase	Freq
1	104.248 V	0.511 A	16.118	
2	0.028 V	0.006 A	127.021	50.023Hz
3	0.807 V	0.316 A	-179.977	Power
4	0.008 V	0.005 A	12.865	51.447 W
5	1.125 V	0.164 A	-15.805	V THD
6	0.008 V	0.005 A	-115.313	1.760 %
7	0.893 V	0.077 A	129.097	A THD
8	0.004 V	0.004 A	85.335	58.332 %
9	0.519 V	0.034 A	-75.822	THC
10	0.003 V	0.002 A	-105.739	0.3669 A
11	0.229 V	0.020 A	55.177	POHC
12	0.004 V	0.001 A	-0.591	0.0099 A
13	0.448 V	0.017 A	-150.797	POHC Max
14	0.025 V	0.001 A	141.951	0.0100 A
15	0.267 V	0.011 A	15.537	
16	0.036 V	0.001 A	-55.169	
17	0.168 V	0.006 A	147.530	
18	0.021 V	0.001 A	83.851	
19	0.117 V	0.006 A	-116.516	
20	0.009 V	0.000 A	-138.508	
21	0.023 V	0.006 A	17.748	

Note

If the power to the target WT is not **ON** or the WT is not ready to make measurements, a communication error occurs when communication is started after selecting the GP-IB address and clicking OK. A communication error also occurs if the GP-IB address is not correct or if there is no response from the target WT.

8. In the Connection dialog box, enter the IP address, user name, and password of the target WT.

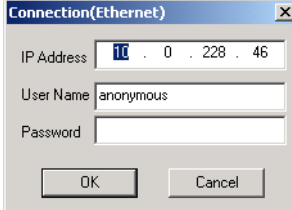

The screenshot shows a dialog box titled "Connection(Ethernet)". It has three input fields: "IP Address" with the value "10.0.228.46", "User Name" with the value "anonymous", and "Password" which is empty. There are "OK" and "Cancel" buttons at the bottom.

Click **OK** to start communications with the target WT. After automatically confirming that communication is possible, an acquisition data window appears. Setup and execution of measurements are now possible.

Acquisition Data Window

For a detailed description of the acquisition data window, see section 3.7.

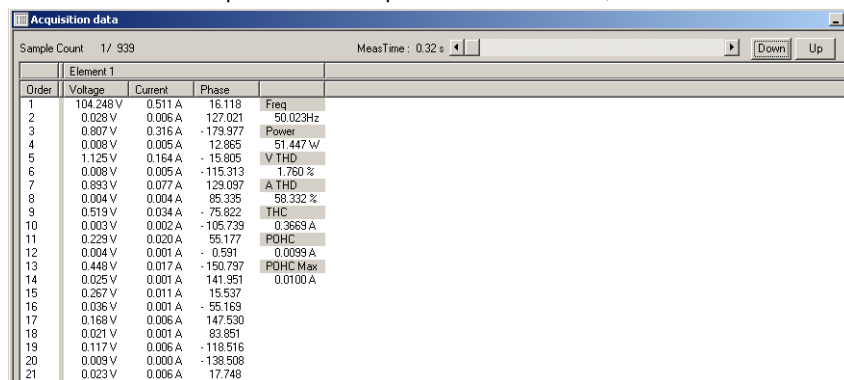

Order	Voltage	Current	Phase	
1	104.248 V	0.511 A	15.118	Freq
2	0.028 V	0.006 A	127.021	50.023Hz
3	0.807 V	0.316 A	-179.977	Power
4	0.008 V	0.005 A	12.865	51.447 W
5	1.125 V	0.164 A	-15.805	V THD
6	0.008 V	0.005 A	-115.313	1.760 %
7	0.893 V	0.077 A	129.097	A THD
8	0.004 V	0.004 A	85.335	58.332 %
9	0.519 V	0.034 A	-75.822	THC
10	0.003 V	0.002 A	-105.739	0.3669 A
11	0.229 V	0.020 A	55.177	POHC
12	0.004 V	0.001 A	-0.591	0.0099 A
13	0.449 V	0.017 A	-152.797	POHC Max
14	0.025 V	0.001 A	141.951	0.0100 A
15	0.267 V	0.011 A	15.537	
16	0.036 V	0.001 A	-55.169	
17	0.168 V	0.006 A	147.530	
18	0.021 V	0.001 A	83.851	
19	0.117 V	0.006 A	-110.516	
20	0.009 V	0.000 A	-138.508	
21	0.023 V	0.006 A	17.748	

Note

If the power to the target WT is not **ON** or the WT is not ready to make measurements, a communication error occurs when communication is started after setting the items in the Connection dialog box and clicking **OK**. A communication error also occurs if the IP address, user name, or password is not correct or if there is no response from the target WT.

Exiting the Software

Choose **Exit** from the **File** menu or click the **X** button in the upper right corner of the Harmonic Analysis Software window. The software program closes.

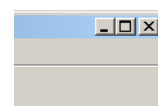
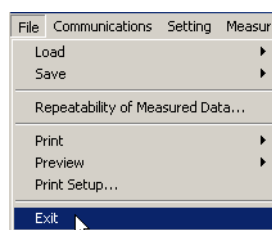

Explanation

A shortcut is located in the Programs folder of the Start menu. You can start the software by selecting the shortcut. The software is saved to the installation destination that was specified during installation described earlier.

Selecting the WT Model

You can select WT3000, WT1600, or WT2000.

If you are using the WT1600 or WT2000, see the Harmonic Analysis Software User's Manual IM761922-01E for the WT1600 or WT2000.

Selecting the Communication Mode

Select Online or Offline.

- **Online**

If you selected Online, you must set the communication interface of the target WT.

- **Offline**

If you selected Offline, communications with the WT is not possible. You can load measured data and setup data that are already saved and display and print the data. Proceed to section 3.8 and continue the operation.

Selecting the Crest Factor (CF)

You can select a crest factor of 3 or 6 on the WT3000. For details on the measurement accuracy and crest factor of the IEC standard, see chapter 10, "Specifications." Highly accurate measurements can be performed by setting the crest factor to 3.

Selecting the Communication Interface

- **GP-IB**

You must select the GP-IB address of the target WT.

- **Ethernet**

You must set the IP address, user name, and password of the target WT.

Selecting the Communication Address

- **GP-IB**

- You can select the GP-IB address of the target WT.
The selectable range is 1 to 30.

- **Ethernet**

- Set the IP address of the target WT.
Selectable range: 0.0.0.0 to 255.255.255.255
- You can set the user name and password of the target WT.
Characters that can be entered on the WT

Starting Communications

Selecting the GP-IB address and clicking OK starts communications with the target WT.

3.1 Initializing the Communication Interface

The procedures described in sections 3.1 and 3.2 are not necessary immediately after starting the software with the communication mode set to On-Line. To change the communication mode from Off-Line to On-Line, follow the procedures given in sections 3.1 and 3.2.

Procedure

1. From the **Communications** menu, choose **Initialize Interface**. The Initialize Interface dialog box opens.

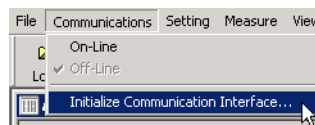

2. Select **CF3** or **CF6**.

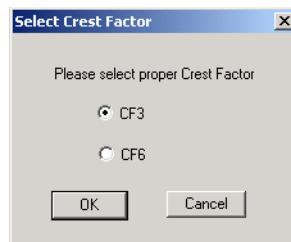

3. Select the communication interface.

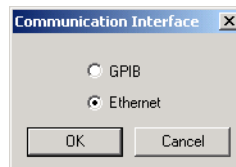

If you selected GP-IB, proceed to step 4.

If you selected Ethernet, proceed to step 5.

4. If you selected GP-IB in step 2, select the GP-IB address for the target WT.

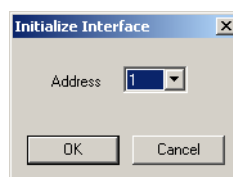

Note

GP-IB address 0 cannot be selected, because it is reserved for use by the PC.

5. If you selected Ethernet in step 3, set the IP address, user name, and password of the target WT.

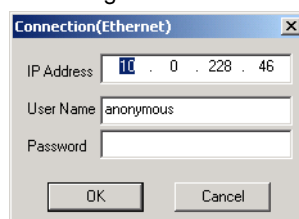

3.1 Initializing the Communication Interface

Explanation

When changing the communication mode from Off-Line to On-Line, you must set the magnitude of the measured current and the communication interface of the target WT.

Selecting the Crest Factor (CF)

You can select a crest factor of 3 or 6 on the WT3000. For details on the measurement accuracy and crest factor of the IEC standard, see chapter 10, "Specifications." Highly accurate measurements can be performed by setting the crest factor to 3.

Selecting the Communication Address

GP-IB

- Select the GP-IB address of the target WT.
The selectable range is 1 to 30.

Ethernet

- Set the IP address of the target WT.
Selectable range: 0.0.0.0 to 255.255.255.255
- Set the user name and password of the target WT.
Selectable characters: Characters that can be entered on the WT

3.2 Enabling On-Line Mode

Procedure

Carry out the procedure below after entering settings on the target instrument according to the procedures given in section 3.1.

1. From the **Communications** menu, choose .

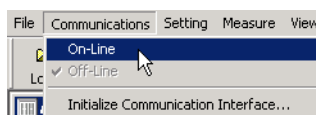

2. Select the crest factor (CF). Communications start with the target WT.

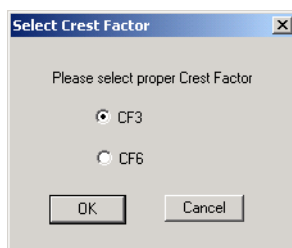

On the status bar of the window, check that Online is indicated.



Note

When starting communications, an error will occur if the power to the target WT is not ON or the WT is not ready to make measurements. A communication error also occurs if the GP-IB address, IP address, user name, or password is incorrect or if there is no response from the target WT.

Explanation

When changing the communication mode from Offline to Online, choose Online from the menu after entering settings of the target WT. When you choose Online from the menu, communications starts with the target WT. When communication begins, harmonic measurement conditions of the WT are loaded into the software.

Selecting the Crest Factor (CF)

You can select a crest factor of 3 or 6 on the WT3000. For details on the measurement accuracy and crest factor of the IEC standard, see chapter 10, "Specifications." Highly accurate measurements can be performed by setting the crest factor to 3.

3.3 Setting the Measurement Conditions of the WT

Procedure

From the **Setting** menu, choose **WT Setting**. The WT Setting dialog box opens. You can also choose **WT Setting** from the **Setup** icon on the toolbar. You can set the measurement conditions of the target WT.

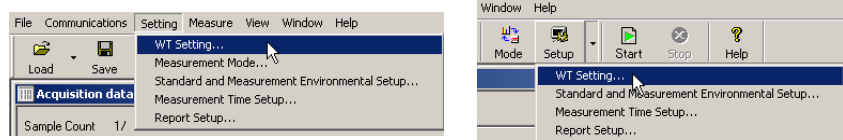

Explanation

The measurement conditions of the WT can be set from this software via the GP-IB or Ethernet interface. For information about the settings, see “Setting Measurement Conditions of the WT” in chapter 8.

3.4 Setting the Measurement Mode to Harmonic Measurement

Procedure

1. From the **Setting** menu, choose **Measurement Mode**. The Measurement mode setup dialog box opens. You can also click  on the toolbar.

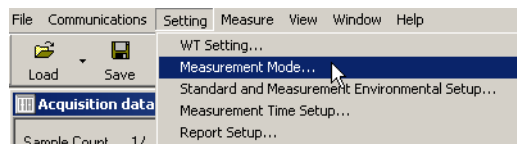

2. Choose **Harmonic Measurement**.
3. Click **OK**. The Acquisition data window opens.
For details on the Acquisition data window, see section 3.7.

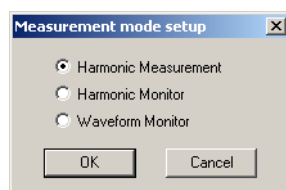

Explanation

To retrieve harmonic measurement data from the WT and evaluate the data according to the IEC or JIS standard (see section 1.3), you must set the measurement mode to Harmonic Measurement. For a description of the function used to display the evaluation results and measured data, see chapter 4.

Measurement Mode

The following three measurement modes are available.

- **Harmonic Measurement Mode**
This mode is used to retrieve harmonics measurement data from the WT and evaluate the data according to the IEC or JIS standard (see section 1.3). When the communication mode is set to On-Line, evaluation can be made according to the IEC standard while making harmonic measurements on the WT. When the communication mode is set to Off-Line, evaluation can be made on the measurement data loaded from files according to the IEC standard.
- **Harmonic Monitor Mode**
Harmonic fluctuation can be monitored on bar graphs and numerical lists while making harmonic measurements on the WT. This mode can be selected only when in On-Line mode.
- **Waveform Monitor Mode**
The measured waveform can be monitored while making harmonic measurements on the WT. This mode can be selected only when in On-Line mode.

Note

When you switch the measurement mode, all the data retrieved and loaded up to that point are cleared. It is recommended that the data retrieved using Harmonic Measurement Mode be saved (see section 6.1) before changing the measurement mode.

3.5 Setting the Standard and Measurement Environment

Procedure

1. From the **Setting** menu, choose **Standard and Measurement Environmental Setup**. The Standard and Measurement Environmental Setup dialog box opens. You can also choose **Standard and Measurement Environmental Setup** from the **Setup** icon on the toolbar.

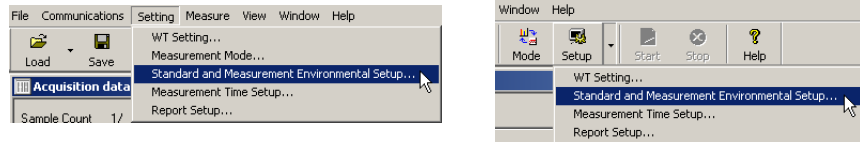

2. Select the applicable standard.

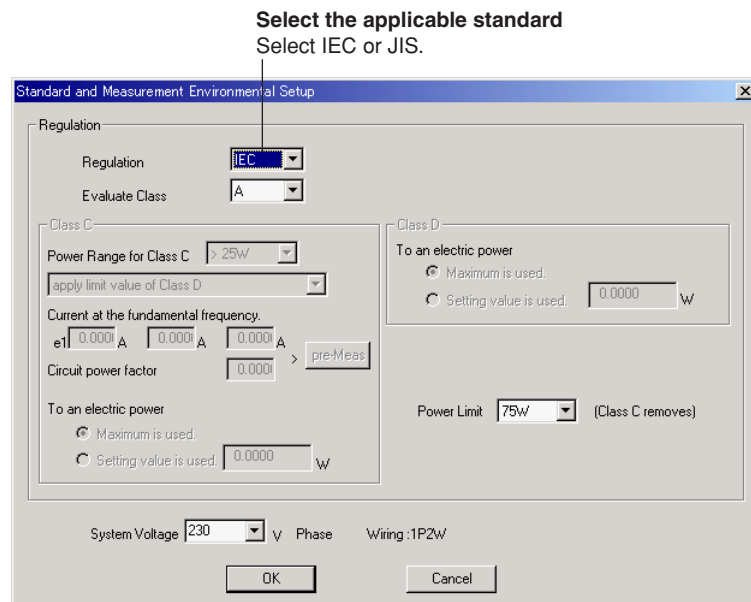

3. From the Evaluate Class list in the Standard and Measurement Environmental Setup dialog box, select the class of the EUT from A, B, C, and D according to the specifications in the applicable standard. The setup information varies depending on the selected class.

Setting Class A or Class B

Set the class according to the explanation in the figure below.

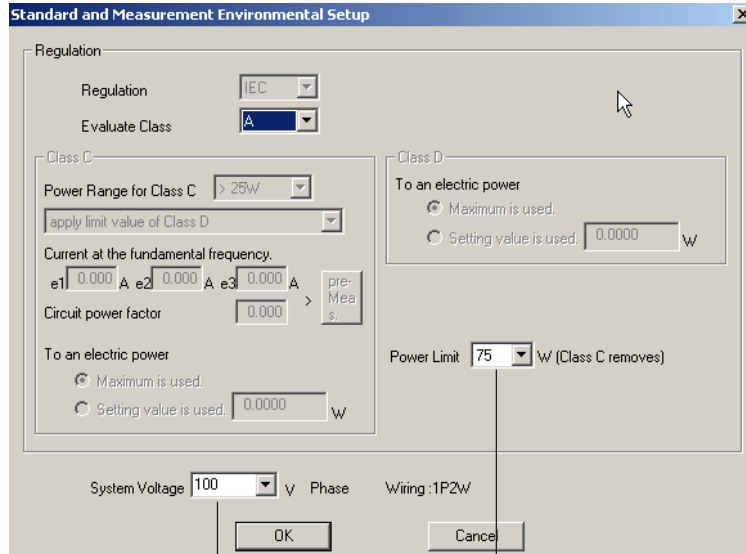

Select the supply voltage

Select the phase voltage or line voltage of the EUT. You can also enter the value. The limits are derived from to the specified system voltage.

Select the lower power limit for applying the limits

Select 50W, 75W, None, or Infinity. When the active power of the EUT is less than the selected power, the limits are not applied.

Select Whether to Apply the Limit for Air Conditioners Exceeding 600 W for JIS Class A

Select whether to apply the limit for air conditioners exceeding 600 W for JIS Class A

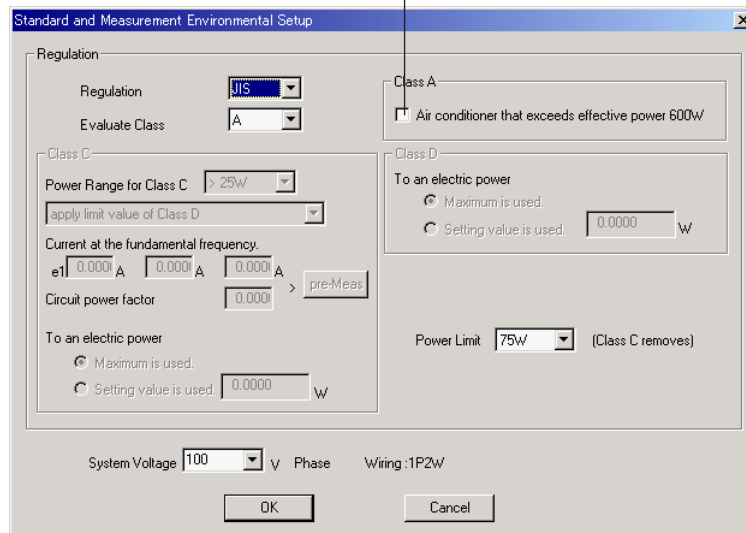

3.5 Setting the Standard and Measurement Environment

Setting Class C

Set the class according to the explanation in the figure below.

- **When the active power from the equipment exceeds 25 W (>25 W)**

Fundamental current

The measured current at the fundamental frequency is displayed for each input element of the WT (e1, e2, and e3 denote element 1, element 2, and element 3, respectively). You can also enter the value.

Measure the fundamental current and power factor

Set the load of the EUT to the maximum and click **Pre-Meas**. The fundamental current and power factor are measured, and the values are displayed (only when online).

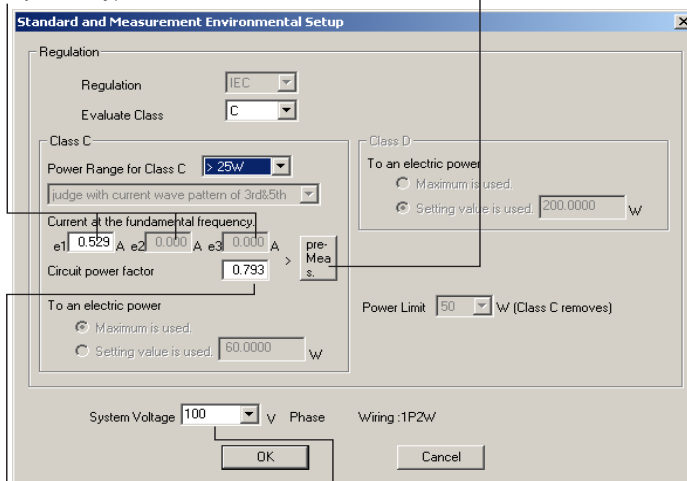

Power factor

The measured power factor is displayed. You can also enter the value.

Set the supply voltage

Set the phase voltage or line voltage of the EUT. You can also enter the value. The limits are derived from the specified system voltage.

- **When the active power from the equipment is less than or equal to 25 W (<=25 W)**

You can select whether to evaluate by applying the power ratio limit of class D or to evaluate on the conditions of harmonic order 3 and 5.

Evaluating by applying the power ratio limits of Class D

Select the power

When applying the power ratio limits of Class D, select to use the maximum power measured by the EUT or a specified power value.

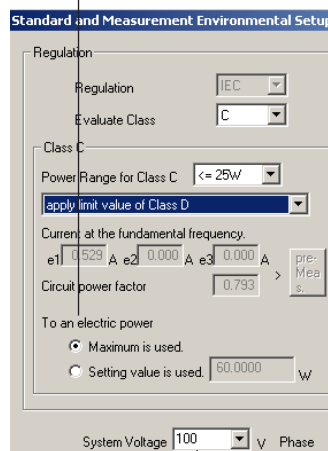

Select the supply voltage

Select the phase voltage or line voltage of the EUT. You can also enter the value. The limits are derived from to the specified system voltage.

Evaluating on the conditions of harmonic order 3 and 5

Measure the fundamental current

Set the load of the EUT to the maximum and click **Pre-Meas**. The fundamental current is measured, and the value is displayed (only when online). You can also enter the value.

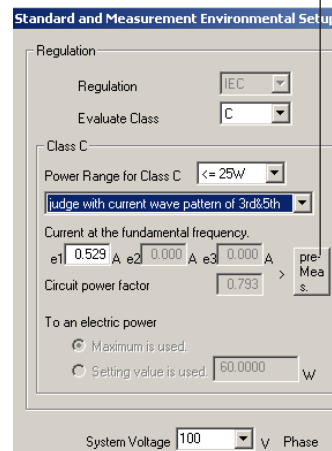

Select the supply voltage

Select the phase voltage or line voltage of the EUT. You can also enter the value. The limits are derived from to the specified system voltage.

Setting Class D

Set the class according to the explanation in the figure below.

Select the power

When applying the power ratio limits of Class D, select to use the maximum power measured by the EUT or a specified power value.

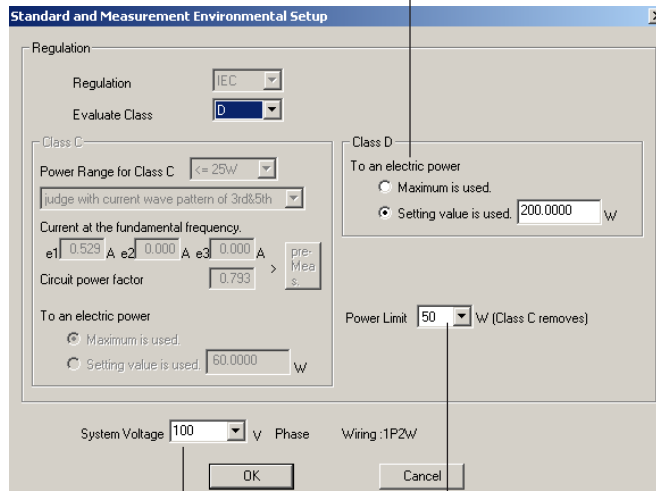

Select the supply voltage

Select the phase voltage or line voltage of the EUT. You can also enter the value. The limits are derived from to the specified system voltage.

Select the lower power limit for applying the limits

Select 50W, 75W, None, or Infinity. When the active power of the EUT is less than the selected power, the limits are not applied.

Explanation

To retrieve harmonic measurement data from the WT and measure/evaluate the data according to the IEC or JIS standard (see section 1.3), you must select the class of the EUT according to the specifications of the applicable standard and set the evaluation conditions in each class. Here, the procedure for switching the evaluation conditions for each class is explained. For a description of the classification specified in the standard and the harmonic limits for each class, see section 1.3 or the applicable standard.

Standard (Regulation)

The software can make measurements and evaluations according to the IEC or JIS standard (see section 1.3).

Class (Evaluate Class)

Select the class from A, B, C, and D, according to the classifications specified in the standard. The setup information varies depending on the class selected here.

Setting Class A

- **Selecting the System Voltage**

You can select the system voltage of the EUT or enter the value. If the wiring system is single-phase two-wire (1P2W), single-phase three-wire (1P3W), or three-phase four-wire (3P4W), select or enter the phase voltage; if the wiring system is three-phase three-wire (3P3W) or three-voltage three-current (3V3A), select or enter the line voltage. The limits are derived from the specified system voltage.

* Depending on the model, the "phase" is denoted as ϕ not P.

- **Selecting the Lower Power Limit for Applying the Limits**

Select 50W, 75W, None, or Infinity. When the active power of the EUT is less than the selected power, the limits are not applied.

- **Selecting Whether to Apply the Limit for Air Conditioners Exceeding 600 W for JIS Class A**

In JIS Class A, special limits are defined for air conditioners that exceed 600 W. You can select whether to apply this limit.

Setting Class B

The setup information is the same as class A. The limits applied are 1.5 times the limits for class A.

Setting Class C When the Active Power of the EUT Exceeds 25 W (>25 W)

- **Selecting the System Voltage**

Same as class A.

- **Measuring the Fundamental Current and Power Factor**

Measure the fundamental current and the power factor of the EUT that are required for defining the limits. Make the measurement by setting the load of the EUT to the maximum.

- **Displaying the Current at the Fundamental Frequency**

The measured current at the fundamental frequency is displayed for each input element of the WT (e1, e2, and e3 denote element 1, element 2, and element 3, respectively). You can also enter the value.

- **Displaying the Power Factor**

The measured power factor is displayed. You can also enter the value.

Setting Class C When the Active Power of the EUT Is Less Than or Equal to 25 W (<=25 W)

The IEC standard specifies that either “the power ratio limits of class D” or “the conditions of harmonic order 3 and 5” are met.

- **Evaluating by Applying the Power Ratio Limits of Class D**

The same power ratio limit of class D is applied.

Selecting the System Voltage

Same as class A.

Selecting the Power

You can select to use the maximum power measured by the EUT or a specified power value.

- **Evaluating on the Conditions of Harmonic Order 3 and 5**

The IEC standard specifies the current ratio of harmonic order 3 and 5 to the fundamental frequency and the relationship between the fundamental current and the current waveform (see page 1-9).

Selecting the System Voltage

Same as class A.

Measuring the Fundamental Current

Measure the fundamental current of the EUT that is required for defining the limits. Make the measurement by setting the load of the EUT to the maximum.

Displaying the Current at the Fundamental Frequency

The measured current at the fundamental frequency is displayed for each input element of the WT (e1, e2, and e3 denote element 1, element 2, and element 3, respectively). You can also enter the value.

Setting Class D

- **Selecting the System Voltage**

Same as class A.

- **Selecting the Power**

You can select to use the maximum power measured by the EUT or a specified power value.

- **Selecting the Lower Power Limit for Applying the Limits**

Select 50W, 75W, None, or Infinity. When the active power of the EUT is less than the selected power, the limits are not applied.

3.6 Setting the Measurement Time

Procedure

1. From the **Setting** menu, choose **Measurement Time Setup**. The Measurement Time Setup dialog box opens. You can also choose **Measurement Time Setup** from the **Setup** icon on the toolbar.

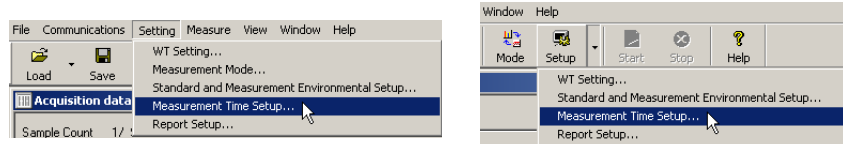

2. Set the measurement time.



Explanation

Measurement Time

The measurement time is the time between the start of the measurement to the end of the measurement. The time for measuring harmonics can be set in advance. The harmonics can be measured continuously for the specified time. The measurement time can be changed when equipment that emits harmonics that fluctuate over time is measured or when confirming that the emitted harmonics do not change even when the equipment is operated over extended time.

Selectable range: 0 H 0 M 1 S to 24 H 0 M 0 S in units of 1 s.

- An error occurs if a time exceeding 24 hours is specified.
- If the measurement time is set to 0 H 0 M 0 S and the measurement is started, measurement continues until you choose Stop from the Measure menu or click Stop on the toolbar.

Note

Depending on the environment of the PC onto which this software was installed, an error occurs if you specify a time longer than the memory area that can be reserved. In this case, you may be able to increase the available time by exiting other applications or by increasing the amount of memory available to the PC.

3.7 Starting and Stopping Measurements (Retrieving Measured Data/Waveform Data)

Procedure

To start measurements and retrieve measurement data, the communication mode must be set to On-Line and the measurement mode must be set to Harmonic Measurement.

Starting Measurements

From the Measure menu, choose Start. The retrieval of the harmonic measurement data measured on the WT starts. The retrieved measurement data is displayed in the Acquisition data window (see the explanation given later). You can also click  on the toolbar.

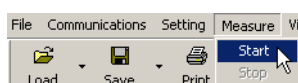

Stopping Measurements

- **Automatically Stopping Measurements**

When the specified measurement time elapses, measurements automatically stop.

- **Aborting Measurements**

From the Measure menu, choose Stop. If the WT is in the middle of measurement, measurement stops after the measurement correctly ends and the retrieval of waveform data is finished. You can also click  on the toolbar.

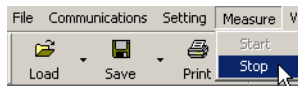

Explanation

Starting/Stopping Measurements

When in On-Line mode, measurement can be started. Measurement cannot be started in Off-Line mode. When measurement is started in Harmonic Measurement mode, the retrieval of the harmonic measurement data measured on the WT starts. When the specified measurement time elapses, measurement is automatically stopped. You can also abort the measurement before the specified measurement time elapses. The waveform data is retrieved immediately after the measurement stops. For a description of the function used to display the measured data and evaluation results, see chapter 4.

Note

When measurement is started in Harmonic Monitor or Waveform Monitor mode, the retrieval of the harmonic measurement data or waveform data measured on the WT starts. These modes are used to monitor the conditions of the harmonics and waveforms and do not evaluate against the standard as in Harmonic Measurement Mode. To stop the measurement and data retrieval in these modes, click Stop. For details, see chapter 5.

3.7 Starting and Stopping Measurements (Retrieving Measured Data/Waveform Data)

Displayed Contents of the Acquisition (Measurement) Data Window

Measurement (acquisition) data number



One set of harmonic measurement data (handled as instantaneous values) consists of harmonic data measured every 200 ms (10 cycles for 50 Hz and 12 cycles for 60 Hz). The software retrieves this data and displays the data as measured data. This example indicates that 751 sets of data have been retrieved and the first measured data is being displayed.

WT input element
The displayed input elements vary depending on the wiring system configuration of the WT.

Meas Time

Indicates the time when the measured data was retrieved. This example indicates the time (0.20 s) when the first measured data was retrieved.

Scroll bar

Drag the  (slider) or click   to select the measured data you wish to display. The Meas Time and the Sample Count number change in sync with the slider position.

Up/Down button

Click to select the displayed measured data one by one. The Meas Time, Sample Count number, and the slider position change in sync each time the Up/Down button is clicked.

Order	Voltage	Current	Phase
1	100.646 V	0.520 A	- 4.087
2	0.060 V	0.001 A	- 83.634
3	1.353 V	0.183 A	- 170.707
4	0.034 V	0.001 A	- 47.468
5	3.281 V	0.059 A	- 173.054
6	0.032 V	0.000 A	- 164.645
7	1.322 V	0.046 A	- 2.596
8	0.019 V	0.000 A	118.583
9	0.257 V	0.016 A	- 34.691
10	0.022 V	0.000 A	- 17.278
11	1.166 V	0.014 A	- 157.684
12	0.024 V	0.000 A	- 98.369
13	0.421 V	0.013 A	85.877
14	0.018 V	0.001 A	27.789
15	0.230 V	0.004 A	10.019
16	0.024 V	0.000 A	127.948
17	0.455 V	0.013 A	- 104.366
18	0.022 V	0.001 A	- 130.938
19	0.365 V	0.005 A	124.721
20	0.018 V	0.000 A	31.907
21	0.112 V	0.009 A	76.700
22	0.024 V	0.000 A	123.822
23	0.181 V	0.008 A	- 33.312
24	0.021 V	0.001 A	- 125.198
25	0.137 V	0.004 A	- 54.986
26	0.019 V	0.001 A	11.749
27	0.165 V	0.008 A	157.578
28	0.025 V	0.001 A	58.668
29	0.132 V	0.003 A	- 153.161
30	0.019 V	0.001 A	- 168.572
31	0.093 V	0.005 A	- 2.959
32	0.020 V	0.001 A	- 111.785
33	0.066 V	0.004 A	68.404
34	0.024 V	0.001 A	11.136
35	0.079 V	0.003 A	- 111.518
36	0.022 V	0.001 A	112.394
37	0.114 V	0.004 A	- 71.564
38	0.023 V	0.001 A	- 151.160
39	0.054 V	0.003 A	118.701
40	0.025 V	0.001 A	- 20.296

Indicates Online or Offline



Model of WT Under Operation Preset measurement time

Time elapsed since the start of measurement (displayed during measurement)

Phase angle of the current of each order with respect to the fundamental current
However, the phase angle displayed on the 1st order line (-4.087° in this example) is the phase angle of the fundamental current with respect to the fundamental voltage.

Current value of each order (rms value)

Voltage value of each order (rms value)

Harmonic orders (orders 1 to 40)

Error Messages during Measurement

The following error message may appear when measurement is executed in Harmonic Measurement mode.

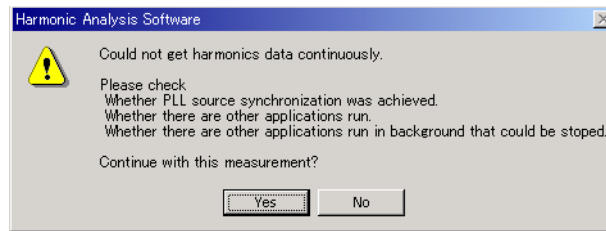

This software retrieves large amount of measured data from the WT. The error message may appear if the CPU on the PC is overloaded and cannot keep up with the data transfer. Lighten the load placed on the CPU on the PC by checking the points listed below.

- Do not operate or run other programs.
- Close memory-resident programs (turn them OFF).
- Disable the standby mode.
- Use the software on a PC that satisfies the system requirements given in section 1.2.

3.8 Switching to Off-Line Mode (Switching from On-Line Mode to Off-Line Mode)

Procedure

From the **Communications** menu, choose **Off-Line**. Communications with the target digital power meter is disconnected and a message “Communication with GPIB was ended” appears.

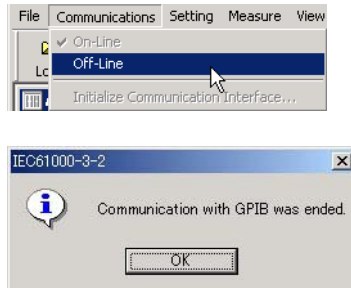

On the status bar of the window, check that Offline is indicated.



Explanation

When the communication mode is changed from On-Line to Off-Line, communications with the target digital power meter is disconnected. You can also make evaluations according to the IEC or JIS standard (see section 1.3) by loading measured data already saved to a file in Off-Line mode. For a description of the function used to display the evaluation results and measured data, see chapter 4.

Note

To change the communication mode from Off-Line back to On-Line, follow the procedures given in sections 3.1 and 3.2.

3.9 Loading Setup Information, Measured Data, and Waveform Data

Procedure

Note

- Setup information, measured data, and waveform data cannot be loaded when the measurement mode is set to Harmonic Monitor or Waveform Monitor.
- If an error occurs while loading the setup information, the settings are reset to their default values.
- If an error occurs while loading setup information, measured data, or waveform data, the data may not be loaded properly. Check the file name and extension, and load the data again.
- Setup information, measured data, and waveform data cannot be loaded while measurement is in progress.

Loading Setup Information

1. From the **File** menu, point to **Load** then choose **Load Setup Information**. The Open dialog box opens. You can also select **Load Setup Information** from the **Load** icon on the toolbar.

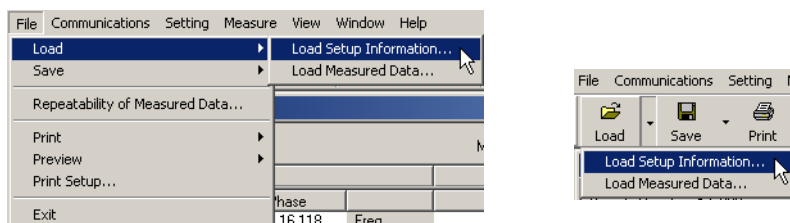

2. Select a file name and click **Open**. The setup information of the selected file is loaded.

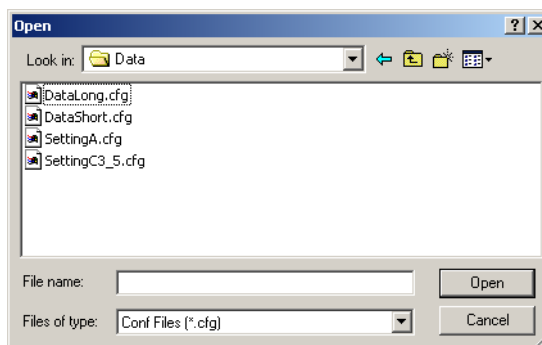

Loading Measured Data, Waveform Data, and Setup Information

Measured data, waveform data, and setup information can be loaded when the measurement mode is set to Harmonic Measurement.

1. From the **File** menu, point to **Load** then choose **Load Measured Data**. The Open dialog box opens. You can also select **Load Measured Data** from the **Load** icon on the toolbar.

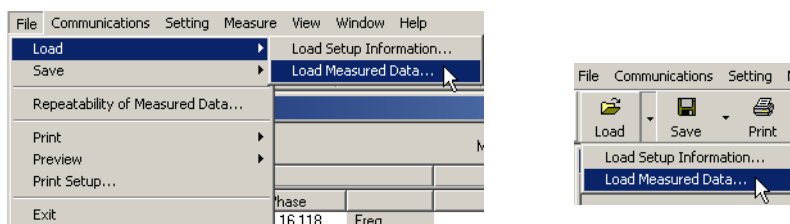

3.9 Loading Setup Information, Measured Data, and Waveform Data

2. Select a file name and click **Open**. The measured data, waveform data, or setup information of the selected file is loaded.

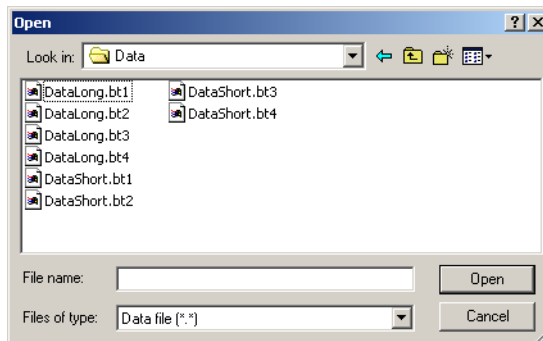

Explanation

Loading Setup Information

The setup information saved in section 6.1 can be loaded.

- The extension of the loaded file is .cfg.
- The details of the setup information are as follows.
 - Measurement mode (see section 3.4).
 - Standard and measurement environment settings (see section 3.5).

The measurement data retrieved from the WT or loaded from a file can be evaluated using the loaded evaluation conditions.

- Measurement time (see section 3.6).
- Display settings (chapters 4 and 5).
- Title/Comment of Reports (see section 7.2).

Reports of measurement data retrieved from the WT or loaded from a file can be saved or printed by attaching the loaded title or comment. For the saving and printing procedure, see chapter 7.

Loading Measured Data, Waveform Data, and Setup Information

- The measurement data, waveform data, and setup information saved in section 6.1 can be loaded.
- Measured data can be loaded when the measurement mode is set to Harmonic Measurement.
- When one of the files with .bt1, .bt2, .bt3, and .bt4 extension is selected in the Open dialog box and loaded, the data of all the files with the same file name in the same directory is loaded. See the following table.

Data Type	Extension	
WT3000	Measured data on the left side of the acquisition data window	.bt1
	Measured data in the center of the acquisition data window	.bt2
	Measured data on the right of the acquisition data window	.bt3
	Measured data common to all input elements	.bt4
	Waveform data on the left side of the acquisition data window	.bw1
	Waveform data in the center of the acquisition data window	.bw2
	Waveform data on the right side of the acquisition data window	.bw3
Harmonic measurement conditions of the WT	.inf	
• If the communication mode is On-Line, the harmonic measurement conditions of the loaded file are applied to "WT Setting" (chapter 8) of the software and transmitted to the WT. If the transmitted harmonic measurement conditions do not match the configuration of the WT, an error message appears. Check the configuration of the connected WT.		
• If the communication mode is Off-Line, the harmonic measurement conditions of the loaded file are applied to "WT Setting" of the software, but not transmitted to the WT. If the mode is switched from Off-Line to On-Line, the harmonic measurement conditions is loaded from the WT into the software.		
Setup information of specifications, evaluation, etc.	.cfg	
Same data as those described in "Setup Information" above.		

3.9 Loading Setup Information, Measured Data, and Waveform Data

Harmonic Analysis Software - Acquisition data

File Communications Setting Measure View Window Help

Load Save Print View Mode Setup Start Stop Help

Acquisition data

Sample Count : 1 / 751 MeasTime : 0.20 s

Element 1				Element 2				Element 3				
Order	Voltage	Current	Phase	Voltage	Current	Phase	Freq	Voltage	Current	Phase	Freq	
1	100.646 V	0.520 A	- 4.087	100.624 V	0.518 A	- 4.079	50.023Hz	100.617 V	0.000 A	0.000	50.023Hz	
2	0.060 V	0.001 A	- 93.634	0.059 V	0.001 A	- 93.536		0.060 V	0.000 A	0.000		
3	1.353 V	0.183 A	- 170.707	1.342 V	0.182 A	- 170.722	Power	1.344 V	0.000 A	0.000	Power	
4	0.034 V	0.001 A	- 47.468	0.034 V	0.001 A	- 46.571	52.273 W	0.034 V	0.000 A	0.000	0.000 W	
5	3.281 V	0.059 A	- 173.054	3.275 V	0.059 A	- 173.303	V THD	3.272 V	0.000 A	0.000	V THD	
6	0.032 V	0.000 A	- 164.645	0.032 V	0.000 A	- 139.208	4.020 %	0.033 V	0.000 A	0.000	4.020 %	
7	1.322 V	0.046 A	2.596	1.321 V	0.046 A	2.511	V THDG	1.333 V	0.000 A	0.000	V THDG	
8	0.019 V	0.000 A	118.583	0.019 V	0.000 A	104.008	4.023 %	0.019 V	0.000 A	0.000	4.022 %	
9	0.257 V	0.016 A	- 34.691	V THDS	0.262 V	0.016 A	- 34.183	V THDS	0.257 V	0.000 A	0.000	V THDS
10	0.022 V	0.000 A	- 112.278	0.022 V	0.000 A	67.502	4.021 %	0.022 V	0.000 A	0.000	4.020 %	
11	1.166 V	0.014 A	- 157.684	A THD	1.174 V	0.014 A	- 158.088	A THD	1.174 V	0.000 A	0.000	A THD
12	0.024 V	0.000 A	- 98.369	38.589 %	0.025 V	0.000 A	- 112.969	38.583 %	0.025 V	0.000 A	0.000	0.000 %
13	0.421 V	0.013 A	85.877	A THDG	0.436 V	0.013 A	85.864	A THDG	0.429 V	0.000 A	0.000	A THDG
14	0.018 V	0.001 A	27.789	38.594 %	0.019 V	0.001 A	94.298	38.588 %	0.019 V	0.000 A	0.000	0.000 %
15	0.230 V	0.004 A	10.019	A THDS	0.232 V	0.004 A	9.657	A THDS	0.232 V	0.000 A	0.000	A THDS
16	0.031 V	0.000 A	127.948	38.590 %	0.024 V	0.000 A	33.746	38.584 %	0.024 V	0.000 A	0.000	0.000 %
17	0.455 V	0.016 A	- 104.366	P THD	0.457 V	0.013 A	- 104.479	P THD	0.457 V	0.000 A	0.000	P THD
18	0.022 V	0.001 A	- 130.938	0.081 %	0.022 V	0.001 A	- 120.631	0.088 %	0.023 V	0.000 A	0.000	0.000 %
19	0.365 V	0.005 A	124.721	THC	0.367 V	0.005 A	125.288	THC	0.369 V	0.000 A	0.000	THC
20	0.018 V	0.000 A	31.907	0.2007 A	0.019 V	0.001 A	29.693	0.1997 A	0.019 V	0.000 A	0.000	0.0000 A
21	0.112 V	0.009 A	76.700	POHC	0.110 V	0.009 A	76.245	POHC	0.113 V	0.000 A	0.000	POHC
22	0.024 V	0.000 A	123.822	0.0173 A	0.024 V	0.000 A	100.721	0.0173 A	0.024 V	0.000 A	0.000	0.0000 A
23	0.181 V	0.008 A	- 33.312	POHC Max	0.178 V	0.008 A	- 34.111	POHC Max	0.177 V	0.000 A	0.000	POHC Max
24	0.021 V	0.001 A	- 125.198	0.0174 A	0.021 V	0.001 A	- 123.558	0.0174 A	0.021 V	0.000 A	0.000	0.0000 A
25	0.137 V	0.004 A	- 54.986		0.139 V	0.004 A	- 56.754		0.135 V	0.000 A	0.000	
26	0.019 V	0.001 A	11.749		0.019 V	0.001 A	- 17.541		0.020 V	0.000 A	0.000	
27	0.165 V	0.008 A	157.578		0.176 V	0.008 A	157.182		0.169 V	0.000 A	0.000	
28	0.025 V	0.001 A	58.668		0.025 V	0.001 A	58.911		0.026 V	0.000 A	0.000	
29	0.132 V	0.003 A	- 153.161		0.134 V	0.003 A	- 153.379		0.132 V	0.000 A	0.000	
30	0.019 V	0.001 A	- 168.572		0.019 V	0.001 A	- 156.431		0.020 V	0.000 A	0.000	
31	0.093 V	0.005 A	- 2.959		0.091 V	0.005 A	- 3.326		0.093 V	0.000 A	0.000	
32	0.020 V	0.001 A	- 111.785		0.020 V	0.001 A	- 89.579		0.020 V	0.000 A	0.000	
33	0.066 V	0.004 A	68.404		0.070 V	0.004 A	68.362		0.067 V	0.000 A	0.000	
34	0.024 V	0.001 A	11.136		0.025 V	0.001 A	- 1.014		0.024 V	0.000 A	0.000	
35	0.079 V	0.003 A	- 111.518		0.077 V	0.003 A	- 114.102		0.079 V	0.000 A	0.000	
36	0.022 V	0.001 A	112.394		0.022 V	0.001 A	137.891		0.022 V	0.000 A	0.000	
37	0.114 V	0.004 A	- 71.564		0.112 V	0.004 A	- 72.954		0.113 V	0.000 A	0.000	
38	0.023 V	0.001 A	- 151.160		0.024 V	0.001 A	- 133.692		0.024 V	0.000 A	0.000	
39	0.054 V	0.003 A	118.701		0.055 V	0.003 A	118.698		0.055 V	0.000 A	0.000	
40	0.025 V	0.001 A	- 20.296		0.026 V	0.001 A	- 22.584		0.025 V	0.000 A	0.000	

Left side of the acquisition data window

Of the elements displayed here:
Measured Data .bt1
Waveform data .bw1

Center of the acquisition data window

Of the elements displayed here:
Measured Data .bt2
Waveform data .bw2

Right side of the acquisition data window

Of the elements displayed here:
Measured Data .bt3
Waveform data .bw3

4.1 Displaying the Evaluation Results over the Entire Measurement Time

Procedure

The input element on which harmonic measurement is made varies depending on the wiring system configuration of the WT (see chapter 8) that you are using. The evaluation of whether the results are within the limits of the applicable standard are made by considering all the input elements specified in the WT wiring system. Below a procedure is given in which the wiring system of the WT3000 is set to single-phase two-wire (1P2W) and one input element is used.

1. From the **View** menu, point to **Overall Evaluation Graph** then choose **Element1**. The Overall Evaluation Graph (Element 1) window opens. You can also choose **View > Overall Evaluation Graph > Element1** from the toolbar.

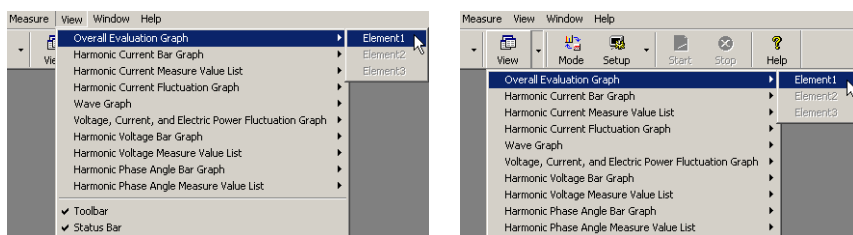

2. Use the scroll bar to set the time zone to be displayed. The evaluation graph of the specified time zone is displayed.

Scroll bar

Drag the (slider) or click to select the time zone you wish to display. The time zone of the evaluation graph changes in sync with the slider position. Active when the measurement time is greater than 150 s.

Display range bar

Displays the position of the time zone specified with the scroll bar with respect to the measurement time.

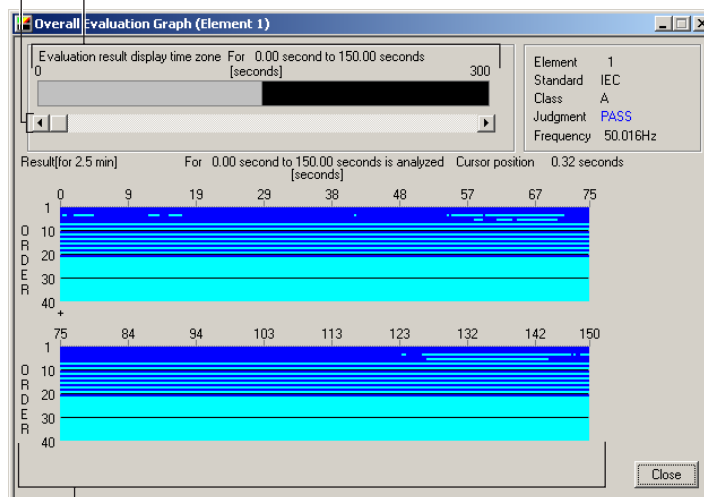

Evaluation graph

Of the measured date, the evaluation results over the time span of 150 s are displayed. The bars of each order are displayed using different colors depending on the result. If you change the time zone to be displayed using the display range bar, the time zone displayed on the evaluation graph changes accordingly. The time span of the evaluation graph, 150 s, does not change.

4.1 Displaying the Evaluation Results over the Entire Measurement Time



Explanation

Evaluation can be made as to whether all of the harmonic measurement data in the measurement time are within the limits according to the settings specified in section 3.6 “Setting the Standard and Measurement Environment,” and the results can be displayed collectively.

The input element on which harmonic measurement is made varies depending on the wiring system configuration of the WT (see chapter 8) that you are using. The evaluation of whether the results are within the limits of the applicable standard are made by considering all the input elements specified in the WT wiring system.

• Overall Evaluation Graph Window

Scroll bar

Drag the  (slider) or click   to select the time zone you wish to display. The time zone of the evaluation graph changes in sync with the slider position. Active when the measurement time is greater than 150 s.

Display range bar

Displays the position of the time zone specified with the scroll bar with respect to the measurement time.

Measurement time (setting value)

Time zone of the evaluation graph

Measurement time

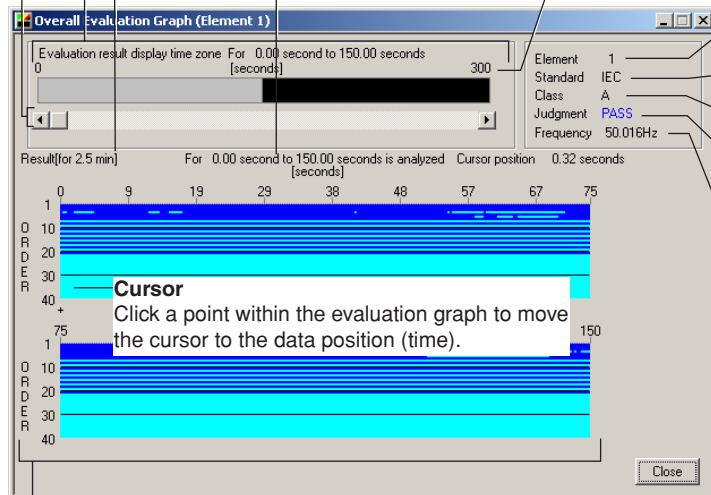

Number of the input element being displayed

In this example, input element 1 is being evaluated.

Applicable standard

This software can make evaluations according to the IEC or JIS standard.

Class

Indicates the class of equipment as specified by the applicable standard.

Judgment

If evaluation of all the data points over the measurement time is blue, bright green, turquoise, or aqua as described on the next page, PASS is indicated. If the evaluation of any data point is yellow, orange, pink, or red, FAIL is indicated.

Fundamental frequency of the PLL source (average)

Displays the average fundamental frequency of the PLL source of the measured data.

Evaluation graph

Of the measured data, the evaluation results over the time span of 150 s (2.5 minutes) are displayed. The bars of each order are displayed using different colors depending on the result. If you change the time zone to be displayed using the display range bar, the time zone displayed on the evaluation graph changes accordingly. The time span of the evaluation graph, 150 s, does not change.

Evaluation Colors

The meaning of the evaluation colors indicated in the evaluation graph is shown in the following table. Below are the conditions of Condition 1, Condition 2, and Relaxation Condition.

- **Condition 1**

The maximum harmonic current over the measurement time is within 1.5 times the specified limit. Evaluation is made on each order.

- **Condition 2**

The mean harmonic current over the measurement time is within the specified limit. Evaluation is made on each order.

- **Relaxation Condition**

If the maximum value of the sum of partial odd harmonic currents (POHC) of order above and including 21 is less than the specified POHC limit, the mean of the odd harmonic currents of order above and including 21 is permitted to be 1.5 times the specified limit.

Blue

Both Conditions 1 and 2 are met. Or, no applicable limits are specified. (If no applicable limits are specified, white is displayed only for the bar graph display described in section 4.2.)

Bright green

- Condition 1 is met.
- Condition 2 is not met.
- Relaxation Condition is met.

Yellow

- Condition 1 is met.
- Condition 2 is not met.
- Relaxation Condition is not met.

Orange

- Condition 1 is not met.
- Condition 2 is met.

Pink

- Condition 1 is not met.
- Condition 2 is not met.
- Relaxation Condition is met.

Red

None of Condition 1, 2, and Relaxation Condition is met.

Turquoise

The measured data is less than the larger of the two values, 0.6% of the mean rms current and 5 mA.

Aqua

- None of Condition 1, 2, and Relaxation Condition is met.
- Excluded from applying the limits because the maximum active power is less than the minimum power (75 W or 50 W) for applying the limits or set to Infinity.

* The names of the sample colors of Microsoft Word or Excel are used for the names of the evaluation colors.

If the evaluation of all the data points over the measurement time is blue, bright green, turquoise, or aqua, Judgment on the Overall Evaluation Graph window indicates PASS. If the evaluation of any data point is yellow, orange, pink, or red, Judgment indicates FAIL.

4.1 Displaying the Evaluation Results over the Entire Measurement Time

Convenient Way of Using the Overall Evaluation Graph

You can select a section of the measured data of interest on the Overall Evaluation Graph and display the instantaneous values on a bar graph or in a list. Below is an example for displaying a bar graph of the harmonic current of input element 1.

1. On the Overall Evaluation Graph, click the section of interest using the mouse. The cursor moves to the data position (time) that was clicked.

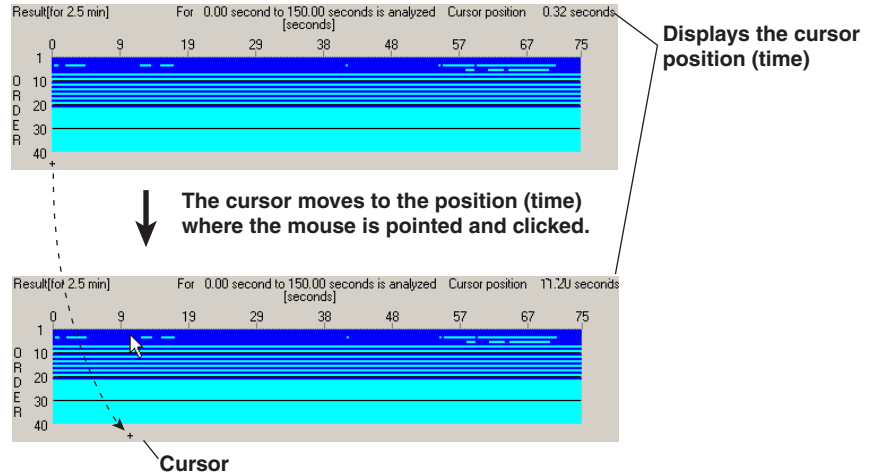

2. From the menu, choose **View > Harmonic Current Bar Graph > Instant Value > Element1**. The instantaneous values of the harmonic currents at the cursor position (time) are displayed on a bar graph.

For a detailed description of the bar graph, see section 4.2.

The section where the level of the harmonic component of order 4 differs and the Judgment changes from blue to turquoise

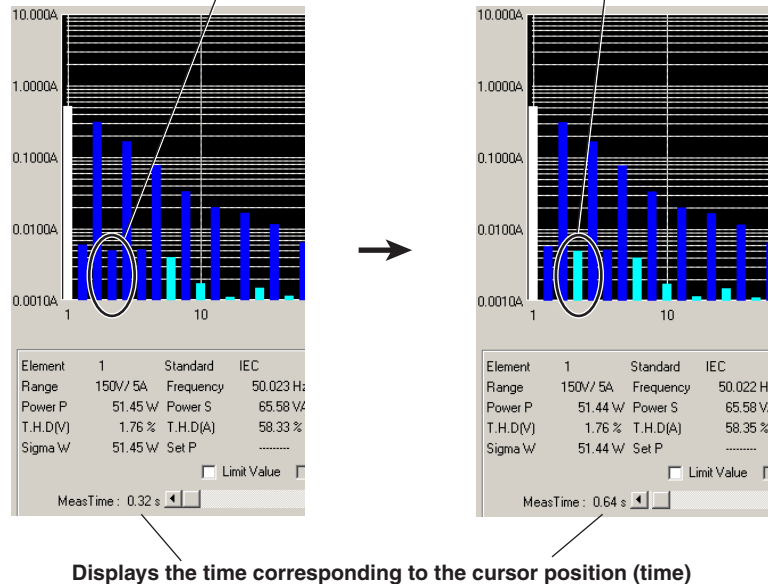

4.2 Displaying the Bar Graph of Harmonic Current/Voltage

Procedure

The input element on which harmonic measurement is made varies depending on the wiring system configuration of the WT (see chapter 8) that you are using. The evaluation of whether the results are within the limits of the applicable standard are made by considering all the input elements specified in the WT wiring system. Below a procedure is given in which the wiring system of the WT3000 is set to single-phase two-wire (1P2W) and one input element is used.

Displaying the Bar Graph of Harmonic Current

From the **View** menu, point to **Harmonic Current Bar Graph** then point to **Maximum**, **Average Value**, or **Instant Value**, and then choose **Element1**. The Harmonic Current Bar Graph (Element 1) window opens. You can also select **View > Harmonic Current Bar Graph > Maximum**, **Average Value**, or **Instant Value > Element1** from the toolbar.

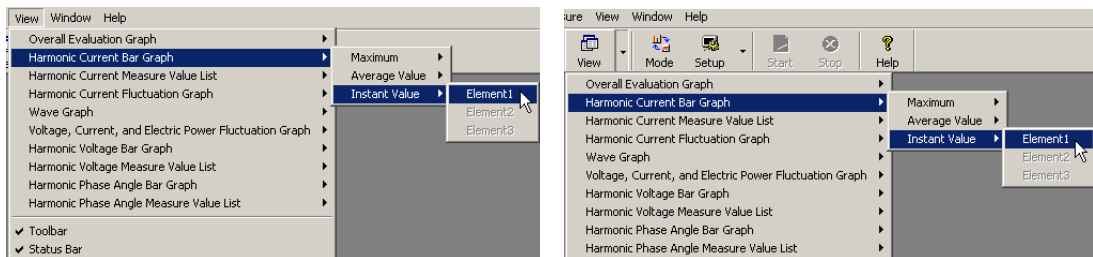

Display Example: Harmonic Current Instant Bar Graph (Element 1)

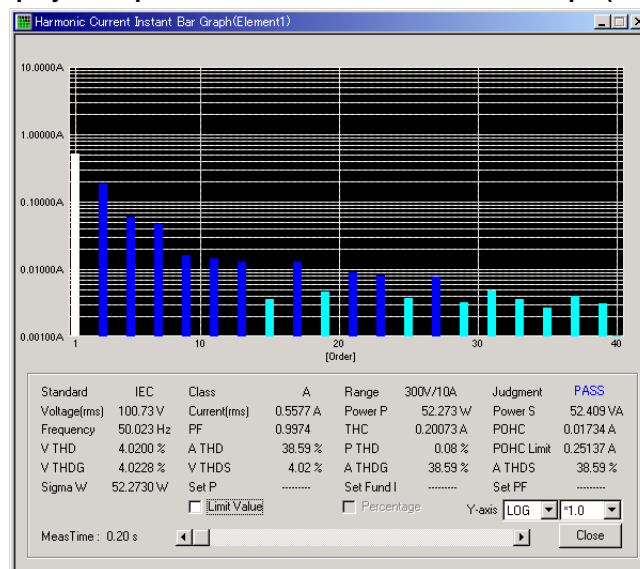

4.2 Displaying the Bar Graph of Harmonic Current/Voltage

Selecting the Y-Axis (Current Magnitude) Scale

- **Selecting the Type of Y-Axis Scale**

Select **LIN** (linear) or **LOG** (logarithmic).



- **Selecting the Magnification**

When the type of scale is LIN, select ***100.0**, ***10.0**, ***5.0**, ***2.0**, ***1.0**, ***0.5**, or ***0.1**.

When the type of scale is LOG, select ***100.0**, ***10.0**, ***1.0**, or ***0.1**.

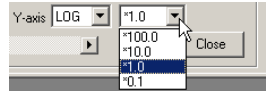

- **Enabling Percentage Display**

Select the **Percentage Display** check box. Y-axis scale, THC, POHC, POHC maximum and POHC limit are displayed in percentages. The relative harmonic content of current of each order can be displayed on bar graphs with the specified fundamental current (fundamental current specified in advance when making Class C evaluation, see section 3.5) taken to be 100%.

Note

The Percentage Display check box becomes selectable under given conditions. The Percentage Display check box becomes selectable when the EUT is of Class C, and ratios are used to evaluate the limits.

Displaying the Limits

Select the **Limit Value** check box. The limits specified in the applicable standard are displayed using yellow bars for each order.

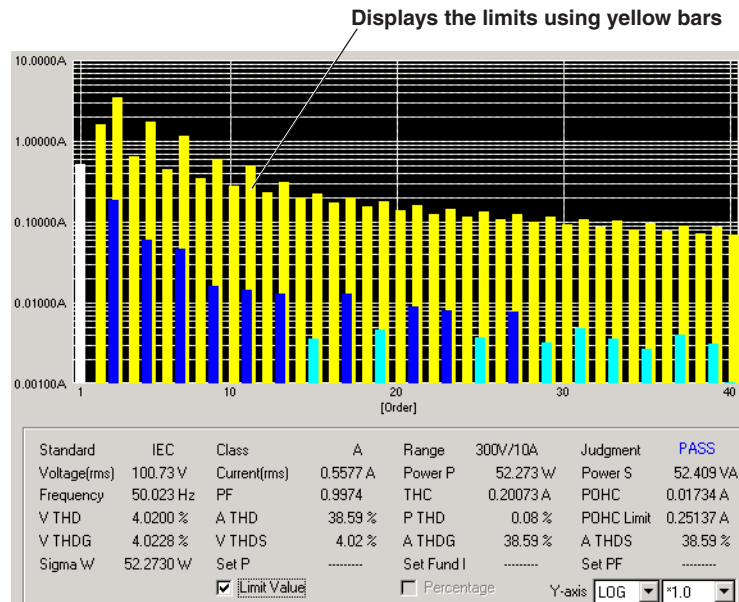

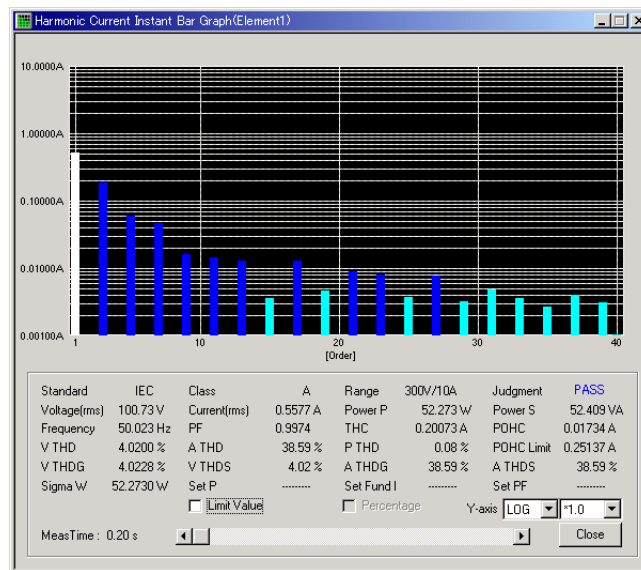

Selecting the Instantaneous Values

On the Harmonic Current Instant Bar Graph window, use the scroll bar to select the instantaneous value to be displayed.



Scroll bar

Drag the  (slider) or click   to select the instantaneous value you wish to display. Meas Time changes in sync with the slider position.

Displaying the Bar Graph of Harmonic Voltage

From the **View** menu, point to **Harmonic Voltage Bar Graph** then point to **Maximum**, **Average Value**, or **Instant Value**, and then choose **Element1**. The Harmonic Voltage Bar Graph (Element 1) window opens. You can also select **View > Harmonic Voltage Bar Graph > Maximum**, **Average Value**, or **Instant Value > Element1** from the toolbar.

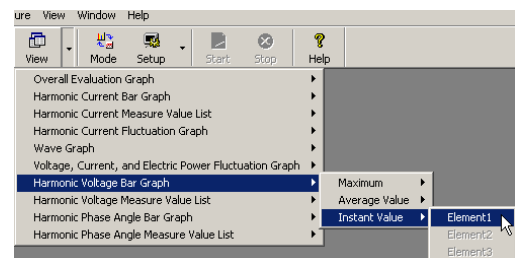
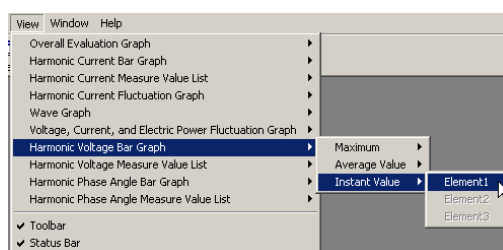

The operations on the Harmonic Voltage Bar Graph window are the same as the operations on the Harmonic Current Bar Graph window. However, because the voltage does not need to be compared and evaluated against the limit, operations for percentage display and limit display are not present. Judgment is not displayed.

4.2 Displaying the Bar Graph of Harmonic Current/Voltage

Explanation

Evaluation can be made as to whether all of the harmonic data in the measurement time are within the limits according to the settings specified in section 3.5 "Setting the Standard and Measurement Environment," and the results can be displayed on bar graphs.

The input element on which harmonic measurement is made varies depending on the wiring system configuration of the WT (see chapter 8) that you are using. The evaluation of whether the results are within the limits of the applicable standard are made by considering all the input elements specified in the WT wiring system.

Here, explanation is given for the bar graph of harmonic current. In the case of the bar graph of harmonic voltage, read "harmonic current" as "harmonic voltage" in the following explanation. However, because the voltage does not need to be compared and evaluated against the limit, the explanation of percentage display and limit display are not applicable.

Harmonic Current Bar Graph Window

Window title

The title is "Harmonic Current Maximum Bar Graph" when the window displays the maximum values of the harmonic current, "Harmonic Current Average Bar Graph" when the window displays the averages, and "Harmonic Current Instant Bar Graph" when the instantaneous values.

Displays the limits using yellow bars

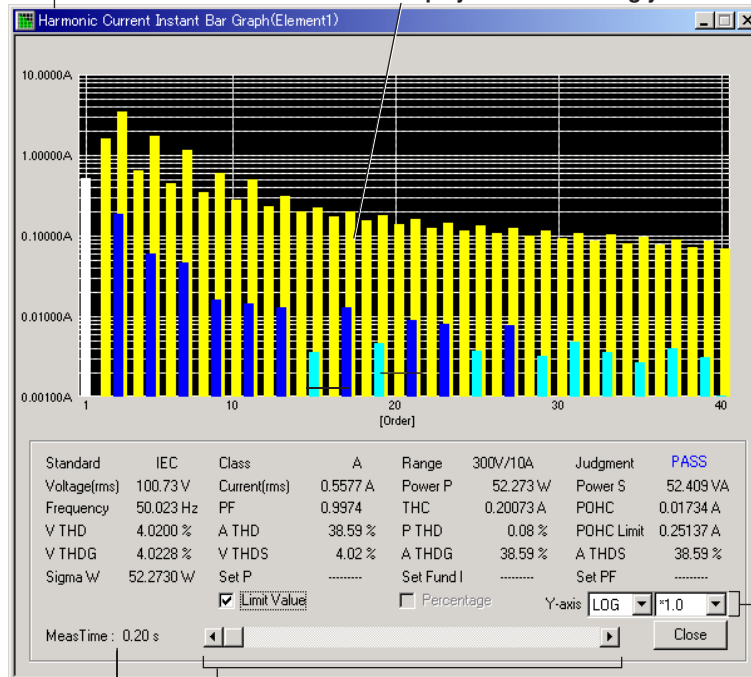

Select the Y-axis scale

Scroll bar (not displayed for maximum and average.)

Drag the (slider) or click to select the instantaneous value you wish to display. Meas Time changes in sync with the slider position.

Meas Time (not displayed for maximum and average.)

Indicates the time when the measured data was retrieved. This example indicates the time (0.2 s) when the first measured data was retrieved.

- **Standard**
Applicable standard. This software can make evaluations according to the IEC standard.
- **Class**
Class of equipment under evaluation Indicates the class of equipment as specified by the applicable standard.
- **Range**
Measurement range selected in the WT configuration (see chapter 8).
- **Judgment**
If evaluation of all the data points over the measurement time is blue, bright green, turquoise, or aqua as described on page 4-3, PASS is indicated. If the evaluation of any data point is yellow, orange, pink, or red, FAIL is indicated.

• **Voltage (rms value)** $\sqrt{\sum_{k=1}^{40} U(k)^2}$
 • **Current (rms value)** $\sqrt{\sum_{k=1}^{40} I(k)^2}$
 • **Active power** $\sum_{k=1}^{40} P(k)$
 • **Apparent power** $\sqrt{\left(\sum_{k=1}^{40} P(k)\right)^2 + \left(\sum_{k=1}^{40} Q(k)\right)^2}$

U(k): rms voltage of each order
 I(k): rms current of each order
 P(k): active power of each order
 Q(k): reactive power of each order
 k: harmonic order

• **Frequency**

Fundamental frequency of the PLL source.

- In the case of the Harmonic Current Maximum Bar Graph (or list), the frequency at which the harmonic current measurement data is maximum within the measurement time (fundamental frequency of the PLL source) is indicated.
- In the case of the Harmonic Current Average Bar Graph (or list), the average value of all frequencies (fundamental frequency of the PLL source) within the measurement time is indicated.
- In the case of the Harmonic Current Instant Bar Graph (or list), the frequency of the individual measurement data point within the measurement time (fundamental frequency of the PLL source) is indicated.

• **PF**

$$\frac{\text{Active power}}{\text{Apparent power}} \times 100$$

For multi-phase equipment, the power factor is derived from the active power and apparent power of all phases. The computing equation of the active power and apparent power of all phases varies depending on the wiring system (see the next page).

• **THC** $\sqrt{\sum_{k=2}^{40} I(k)^2}$
 • **V THD** $\frac{\sqrt{\sum_{k=2}^{40} U(k)^2}}{U(1)} \times 100$
 • **A THD** $\frac{\sqrt{\sum_{k=2}^{40} I(k)^2}}{I(1)} \times 100$
 • **P THD** $\left| \frac{\sum_{k=2}^{40} P(k)}{P(1)} \right| \times 100$

U(k): rms voltage of each order, U(1): rms voltage of the fundamental signal
 I(k): rms current of each order, I(1): rms current of the fundamental signal
 P(k): active power of each order, P(1): active power of the fundamental signal
 k: harmonic order

• **V THDG** $\frac{\sqrt{\sum_{k=2}^{40} U_g(k)^2}}{U_g(1)} \times 100$
 • **V THDS** $\frac{\sqrt{\sum_{k=2}^{40} U_{sg}(k)^2}}{U_{sg}(1)} \times 100$

U_g(k): Rms value of the harmonic group of each order
 U_{sg}(k): Rms value of the harmonic subgroup of each order
 k: harmonic order

• **A THDG** $\frac{\sqrt{\sum_{k=2}^{40} I_g(k)^2}}{I_g(1)} \times 100$
 • **A THDS** $\frac{\sqrt{\sum_{k=2}^{40} I_{sg}(k)^2}}{I_{sg}(1)} \times 100$

I_g(k): Rms value of the harmonic group of each order
 I_{sg}(k): Rms value of the harmonic subgroup of each order
 k: harmonic order

4.2 Displaying the Bar Graph of Harmonic Current/Voltage

- **POHC**

Displayed on Instant Bar Graph (or list).

$$\sqrt{\sum_{k=21, 23}^{39} I(k)^2}$$

I(k): rms current of odd harmonics above and including order 21

k: harmonic order, odd value above and including 21

- **POHC Max**

Displayed on Maximum and Average Bar Graphs (or lists). POHC maximum derived from individual measured data points within the measurement time. If this value is less than the POHC Limit below, the relaxation condition (see page 4-3) is applied.

- **POHC Limit**

$$\sqrt{\sum_{k=21, 23}^{39} I_L(k)^2}$$

I_L(k): Limits of even harmonics above and including 21 as specified by the applicable standard

k: harmonic order, odd value above and including 21

- **Sigma W**

The computing equation of the active power of all phases, Sigma W, varies depending on the wiring system.

WT3000

Wiring System	Sigma W Equation	Apparent Power of All Phases
1P2W	Active power of each input element	Apparent power of each input element
1P3W	W1+W2	VA1+VA2
3P3W	W1+W2	(VA1+VA3) ×√3/2
3V3A	W1+W2	(VA1+VA2+VA3)×√3/3
3P4W	W1+W2+W3	VA1+VA2+VA3

* W1, W2, and W3 are the active power values displayed in the corresponding position in the acquisition data window. VA1, VA2, and VA3 are the apparent power values displayed in the corresponding position in the acquisition data window.

Note

- When applying the power ratio limit on Class C or D multi-phase equipment, the harmonic current per watt derived from the total active power (Sigma W) of all phases (three phases if three-phase) and the power ratio limit are compared and evaluated.
- Equipment whose Sigma W exceeds 600 W is considered Class A equipment under the standard. Use caution because the software makes evaluations using the class selected in standard and measurement environment settings (see section 3.5).

- **Set P, Set Fund I, and Set PF**

For Set P, the power value (see section 3.5) specified in advance is displayed when making Class C or D evaluations.

For Set Fund I and Set PF, the fundamental current and power factor values (see section 3.5) specified in advance are displayed respectively when making Class C evaluations.

Note

If the Percentage Display check box is selected, the Y-axis scale, THC, POHC, POHC maximum and POHC limit are displayed in percentages.

Displaying the Limits

- If the Limit Value check box is selected, the limits specified in the applicable standard are displayed using yellow bars for each order.
- The limits are applied only to harmonic current.

- When limits are specified by the relative harmonic content of order 3 and 5 such as the limits for Class C equipment with active input power less than or equal to 25 W, bars of magnitude corresponding to the current values converted from the relative harmonic content of order 3 and 5 with the fundamental current specified in advance (see section 3.5) taken to be 100% are displayed.

Bar Graph Type and Displayed Contents

Three types of harmonic current bar graphs are available: maximum bar graph, average bar graph, and instantaneous bar graph. The meanings of the displayed items which vary depending on the bar graph are explained below.

• Items Displayed on the Maximum Bar Graph

- Bar displayed for each order
For each order, the individual measured data points (instantaneous values) within the measurement are compared, and the maximum value is displayed.
- Items displayed at the bottom section of the bar graph
The items described on pages 4-8 and 4-10 are displayed.
For each item, the values derived from individual measured data points (instantaneous values) within the measurement are compared, and the maximum value is displayed.
- Limit bar
Yellow bars that are 1.5 times the magnitude of the limits specified by the applicable standard are displayed.

• Items Displayed on the Average Bar Graph

- Bar displayed for each order
For each order, the individual measured data points (instantaneous values) within the measurement are averaged, and the average value is displayed.
- Measurement items displayed at the bottom section of the bar graph
The items described on pages 4-8 and 4-10 are displayed.
For each item, the values derived from individual measured data points (instantaneous values) within the measurement are averaged, and the average value is displayed.
- Limit bar
Yellow bars that correspond to the magnitude of the limits specified by the applicable standard are displayed.

• Items Displayed on the Instantaneous Bar Graph

- Bar displayed for each order
For each order, the individual measured data points (instantaneous values) within the measurement time are displayed.
- Measurement items displayed at the bottom section of the bar graph
The items described on pages 4-8 and 4-10 are displayed.
Values derived from individual measured data points within the measurement time are displayed.
- Limit bar
Yellow bars that are 1.5 times the magnitude of the limits specified by the applicable standard are displayed.
- Instantaneous values
You can use the scroll bar to select the instantaneous values to be displayed.

Selecting the Y-Axis (Current Magnitude) Scale

• Type of Y-Axis Scale

You can select LIN (linear) or LOG (logarithmic).

• Selecting the Magnification

When the type of scale is LIN, you can select *100.0, *10.0, *5.0, *2.0, *1.0, *0.5, or *0.1.

When the type of scale is LOG, you can select *100.0, *10.0, *1.0, or *0.1.

4.2 Displaying the Bar Graph of Harmonic Current/Voltage







- When set to *1.0, the maximum value of the Y-axis LIN scale is the value of the measurement range selected in the WT configuration (see chapter 8). The maximum value of the LOG scale is one digit above the measurement range, value that is 10 to an integer power.
- **Percentage Display**

If the Percentage Display check box is selected, the Y-axis scale, THC, POHC, POHC maximum and POHC limit can be displayed in percentages. The relative harmonic content of current of each order can be displayed on bar graphs with the specified fundamental current (fundamental current specified in advance when making Class C evaluation, see section 3.5) taken to be 100%.

 - When the magnification of the Y-axis scale is *1.0, the maximum scale of Y-axis is 100.00%.
 - The Percentage Display check box becomes selectable under given conditions. The Percentage Display check box becomes selectable when the EUT is of Class C, and ratios are used to evaluate the limits (see section 1.3).
 - The percentage display is applied only to harmonic current.
 - When limits are specified by the relative harmonic content of order 3 and 5 such as the limits for Class C equipment with active input power less than or equal to 25 W, bars corresponding to the magnitude of the values are displayed.

Color of Bars

The bar graph that is displayed for each order is displayed using a length converted from the magnitude of the measured data. The meaning of the colors is indicated in the following table.

	Blue Limit not exceeded.
	Bright green (applies only to average bar graph) When the same conditions of bright green on page 4-3 applies.
	Red Limit exceeded.
	White No applicable limit is specified. (The bar graph of the fundamental frequency and orders that are not applicable is displayed in white.)
	Yellow Limit specified by the applicable standard.
	Turquoise The measured data is less than the larger of the two values, 0.6% of the mean rms current and 5 mA.
	Aqua <ul style="list-style-type: none">• Limit exceeded.• Excluded from applying the limits because the maximum active power is less than the minimum power (75 W or 50 W) for applying the limits or set to Infinity.

* The names of the sample colors of Microsoft Word or Excel are used for the names of the colors.

Bar graphs of harmonic voltage are displayed in white. Harmonic voltage does not need to be compared and evaluated against the limit.

Mutual Relationship of Graphs and Lists

When using the scroll bar to select the time of acquisition and displaying the measured data on a graph window or list window displaying a certain instantaneous value, the other graph window or list window also shows the measured data at the same time of acquisition.

4.3 Displaying the List of Harmonic Current/Voltage

Procedure

The input element on which harmonic measurement is made varies depending on the wiring system configuration of the WT (see chapter 8) that you are using. The evaluation of whether the results are within the limits of the applicable standard are made by considering all the input elements specified in the WT wiring system. Below a procedure is given in which the wiring system of the WT3000 is set to single-phase two-wire (1P2W) and one input element is used.

Displaying the List of Harmonic Current

From the **View** menu, point to **Harmonic Current Measure Value List** then point to **Maximum**, **Average Value**, or **Instant Value**, and then choose **Element1**. The Harmonic Current List (Element 1) window opens. You can also select **View > Harmonic Current Measure Value List > Maximum**, **Average Value**, or **Instant Value > Element1** from the toolbar.

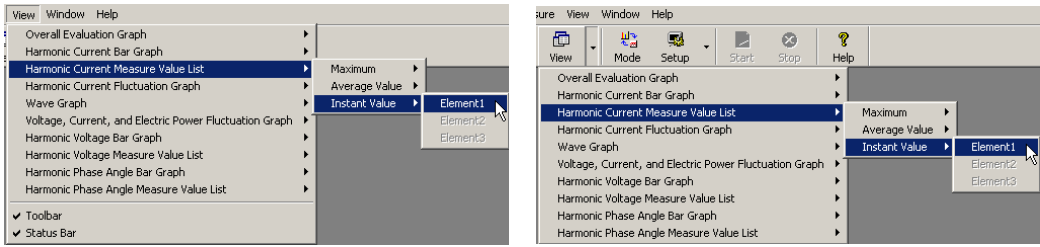

Display Example: Harmonic Current Instant Value List (Element 1)

Order	Measure [A]	Limit [A]	Margin [%]
1	0.52028		
2	0.00095	1.62000	99.9
3	0.18308	3.45000	94.7
4	0.00057	0.64500	99.9
5	0.05935	1.71000	96.5
6	0.00047	0.45000	99.9
7	0.04599	1.15500	96.0
8	0.00050	0.34500	99.9
9	0.01596	0.60000	97.3
10	0.00038	0.27600	99.9
11	0.01416	0.49500	97.1
12	0.00044	0.23000	99.8
13	0.01294	0.31500	95.9
14	0.00052	0.19714	99.7
15	0.00362	0.22500	98.4
16	0.00043	0.17250	99.8
17	0.01303	0.19853	93.4
18	0.00055	0.15333	99.6
19	0.00463	0.17763	97.4
20	0.00047	0.13800	99.7
21	0.00892	0.16071	94.5
22	0.00048	0.12545	99.6
23	0.00815	0.14674	94.4
24	0.00060	0.11500	99.5
25	0.00374	0.13500	97.2
26	0.00059	0.10615	99.4
27	0.00784	0.12500	93.7
28	0.00064	0.09857	99.4
29	0.00323	0.11538	97.2
30	0.00075	0.09200	99.2
31	0.00483	0.10887	95.6
32	0.00061	0.08625	99.3
33	0.00358	0.10227	96.5
34	0.00083	0.08118	99.0
35	0.00273	0.09643	97.2
36	0.00088	0.07667	98.9
37	0.00397	0.09122	95.6
38	0.00081	0.07263	98.9

Element	1
Standard	IEC
Class	A
Judgment	PASS
Range	300V/10A
Frequency	50.023 Hz
Voltage(ms)	100.73 V
Current(ms)	0.5577 A
Power P	52.273 W
Power S	52.409 VA
PF	0.9974
V THD	4.02 %
V THDS	4.02 %
V THDG	4.02 %
A THD	38.59 %
A THDS	38.59 %
A THDG	38.59 %
P THD	0.08 %
THC	0.20073 A
POHC	0.01734 A
POHC Limit	0.25137 A
Sigma W	52.2730 W
Set P
Set Fund I
Set PF

MeasTime: 0.20 s

4.3 Displaying the List of Harmonic Current/Voltage

Enabling Percentage Display

Select the **Percentage Display** check box. Measured value, limit, THC, POHC, POHC maximum and POHC limit are displayed in percentages. The relative harmonic content of current of each order can be displayed in the Measure and Limit columns with the specified fundamental current (fundamental current specified in advance when making Class C evaluation, see section 3.5) taken to be 100%.

Note



The Percentage Display check box becomes selectable under given conditions. The Percentage Display check box becomes selectable when the EUT is of Class C, and ratios are used to evaluate the limits.

Selecting the Instantaneous Value

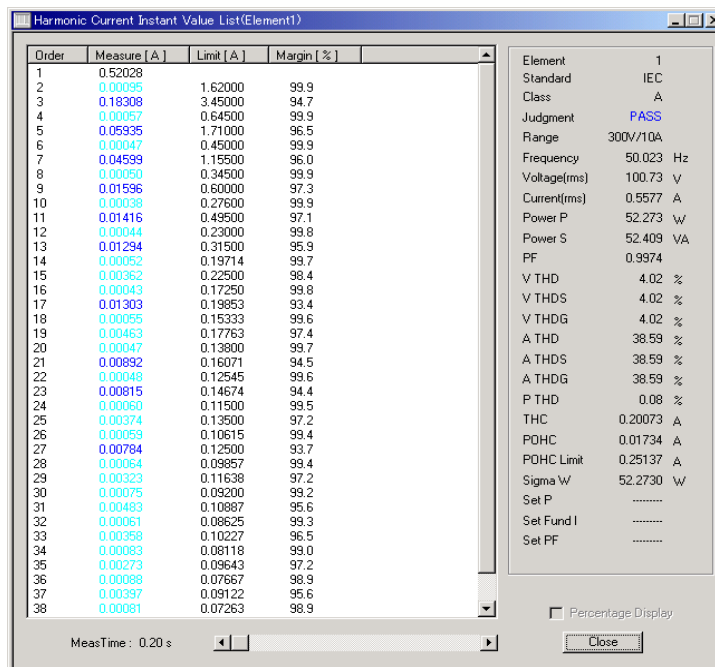
On the Harmonic Current Measure Value List window, you can use the scroll bar to select the instantaneous values to be displayed.



Scroll bar

Drag the  (slider) or click   to select the instantaneous value you wish to display. Meas Time changes in sync with the slider position.

Displaying the List of Harmonic Voltage

From the **View** menu, point to **Harmonic Voltage Measure Value List** then point to **Maximum**, **Average Value**, or **Instant Value**, and then choose **Element1**. The Harmonic Voltage List (Element 1) window opens. You can also select **View > Harmonic Voltage Measure Value List > Maximum**, **Average Value**, or **Instant Value > Element1** from the toolbar.

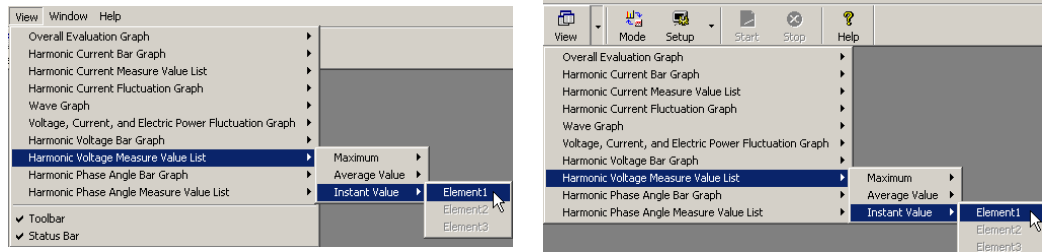

The operations on the Harmonic Voltage List window are the same as the operations on the Harmonic Current List window. However, because the voltage does not need to be compared and evaluated against the limit, operations for percentage display are not present. Judgment, limit, and margin are not displayed.

4.3 Displaying the List of Harmonic Current/Voltage

Explanation

Evaluation can be made as to whether all of the harmonic data in the measurement time are within the limits according to the settings specified in section 3.5 “Setting the Standard and Measurement Environment,” and the results can be displayed in a list.

The input element on which harmonic measurement is made varies depending on the wiring system configuration of the WT (see chapter 8) that you are using. The evaluation of whether the results are within the limits of the applicable standard are made by considering all the input elements specified in the WT wiring system.

Here, explanation is given for the list of harmonic current. In the case of the list of harmonic voltage, read “harmonic current” as “harmonic voltage” in the following explanation. However, because the voltage does not need to be compared and evaluated against the limit, the explanation of judgment, percentage display, limit, and margin are not applicable.

Harmonic Current List Window

Window title

The title is "Harmonic Current Maximum List" when the window displays the maximum values of the harmonic current, "Harmonic Current Average List" when the window displays the averages, and "Harmonic Current Instant List" when the instantaneous values.

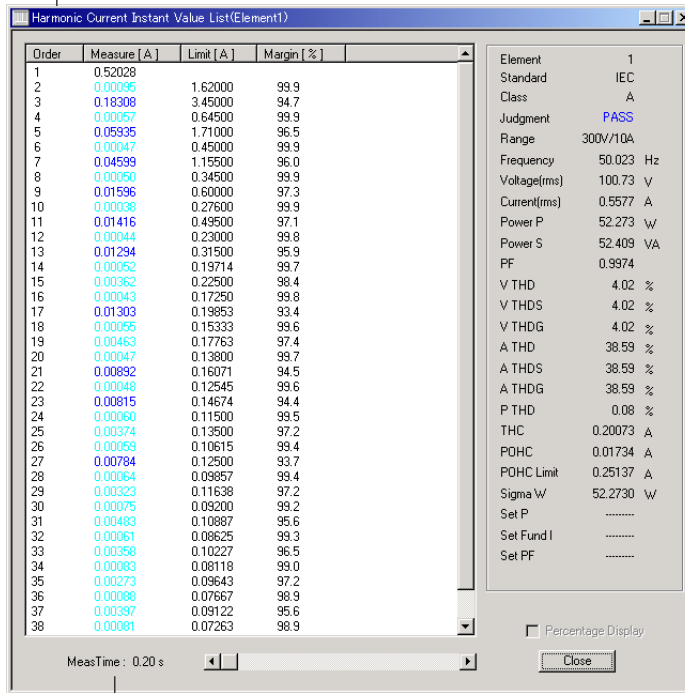

Scroll bar (not displayed for maximum and average.)

Drag the [] (slider) or click [] [] to select the instantaneous value you wish to display. Meas Time changes in sync with the slider position.

Meas Time (not displayed for maximum and average.)

Indicates the time when the measured data was retrieved. This example indicates the time (0.20 s) when the first measured data was retrieved.

For a description of the items from Element to Set PF in the list window, see the explanation in section 4.2, “Displaying the Bar Graph of Harmonic Current/Voltage” (page 4-8).

Limit

- The limits specified in the applicable standard are displayed in a list for each order.
- The limits are applied only to harmonic current.
- If the Percentage Display check box is selected, the relative harmonic content of the limit of each order can be displayed with the specified fundamental current (fundamental current specified in advance when making Class C evaluation, see section 3.6) taken to be 100%.
- When limits are specified by the relative harmonic content of order 3 and 5 such as the limits for Class C equipment with active input power less than or equal to 25 W, the current value converted from the relative harmonic content of order 3 and 5 with the fundamental current specified in advance (see section 3.6) taken to be 100% is displayed.

Margin

Indicates the margin to the limit. For each order, the margin is derived from the following equation using the limits and measured values displayed in the list.

$$\frac{\text{Limit} - \text{measured value}}{\text{Limit}} \times 100$$

List Type and Displayed Contents

Three types of harmonic current lists are available: maximum list, average list, and instantaneous list. The meanings of the displayed items which vary depending on the list are explained below.

- **Items Displayed on the Maximum List**

- Measured value displayed for each order
For each order, the individual measured data points (instantaneous values) within the measurement are compared, and the maximum value is displayed.
- Items displayed in the right column of the list
The items described on pages 4-8 and 4-10 are displayed.
For each item, the values derived from individual measured data points (instantaneous values) within the measurement are compared, and the maximum value is displayed.
- Limit
Indicates values that are 1.5 times the limits specified by the applicable standard.

- **Items Displayed on the Average List**

- Measured value displayed for each order
For each order, the individual measured data points (instantaneous values) within the measurement are averaged, and the average value is displayed.
- Items displayed in the right column of the list
The items described on pages 4-8 and 4-10 are displayed.
For each item, the values derived from individual measured data points (instantaneous values) within the measurement are averaged, and the average value is displayed.
- Limit
Indicates the limits specified by the applicable standard.

4.3 Displaying the List of Harmonic Current/Voltage

- **Items Displayed on the Instantaneous List**

- Measured value displayed for each order
For each order, the individual measured data points (instantaneous values) within the measurement time are displayed.
- Items displayed in the right column of the list
The items described on pages 4-8 and 4-10 are displayed.
Values derived from individual measured data points within the measurement time are displayed.
- Limit
Indicates values that are 1.5 times the limits specified by the applicable standard.
- Instantaneous values
You can use the scroll bar to select the instantaneous values to be displayed.







Percentage Display

If the Percentage Display check box is selected, the THC, POHC, POHC maximum and POHC limit can be displayed in percentages. The relative harmonic content of the measured value or limit of each order can be displayed with the specified fundamental current (fundamental current specified in advance when making Class C evaluation, see section 3.5) taken to be 100%.

- The Percentage Display check box becomes selectable under given conditions.
The Percentage Display check box becomes selectable when the EUT is of Class C, and ratios are used to evaluate the limits (see section 1.3).
- The percentage display is applied only to harmonic current.
- When limits are specified by the relative harmonic content of order 3 and 5 such as the limits for Class C equipment with active input power less than or equal to 25 W, the values are displayed.

Color of Measured Values

The meaning of the colors of the measured values displayed for each order is indicated in the following table.

 Blue	Limit not exceeded.
 Bright green (applies only to average list)	When the same conditions of bright green on page 4-3 applies.
 Red	Limit exceeded.
 Black	No applicable limit is specified. (The measured value of the fundamental frequency and orders that are not applicable is displayed in black.)
 Turquoise	The measured data is less than the larger of the two values, 0.6% of the mean rms current and 5 mA.
 Aqua	<ul style="list-style-type: none">• Limit exceeded.• Excluded from applying the limits because the maximum active power is less than the minimum power (75 W or 50 W) for applying the limits or set to Infinity.

* The names of the sample colors of Microsoft Word or Excel are used for the names of the colors.

The measured value of harmonic voltage are displayed in black. Harmonic voltage does not need to be compared and evaluated against the limit.

Mutual Relationship of Graphs and Lists

See the explanation in section 4.2, "Displaying the Bar Graph of Harmonic Current/Voltage" (page 4-12).

4.4 Displaying the Bar Graph of the Harmonic Current Fluctuation

Procedure

The input element on which harmonic measurement is made varies depending on the wiring system configuration of the WT (see chapter 8) that you are using. Below a procedure is given in which the wiring system of the WT3000 is set to single-phase two-wire (1P2W) and one input element is used.

Displaying the Harmonic Current Change Graph Window

From the **View** menu, point to **Harmonic Current Fluctuation Graph** then choose **Element1**. The Harmonic Current Fluctuation Graph (Element 1) window opens. You can also choose **View > Harmonic Current Fluctuation Graph > Element1** from the toolbar.

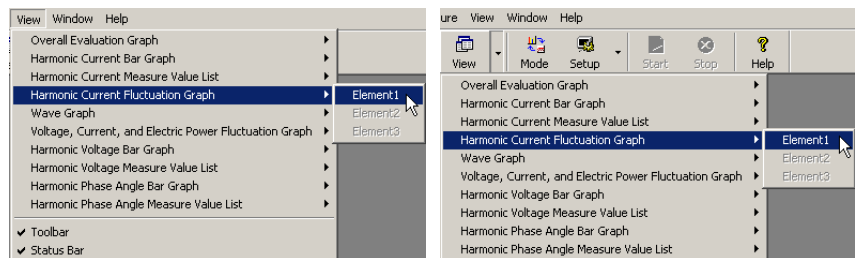

Display Example: Harmonic Current Fluctuation Graph (Element 1)

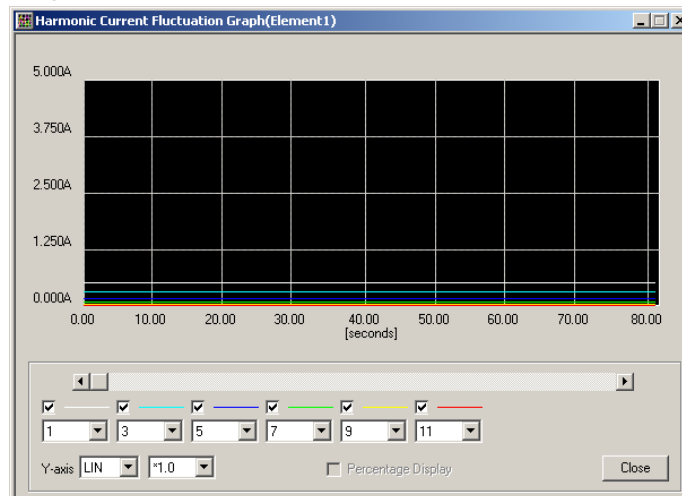

Selecting the Order of Current to Be Displayed

From the order selection box, select a value from 1 to 40 or THC.

The maximum number of graph lines that can be displayed is 6.

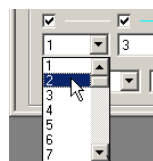

Order selection box

4.4 Displaying the Bar Graph of the Harmonic Current Fluctuation

Showing/Hiding the Graph

Use the show/hide check box to select whether to show or hide the graph.

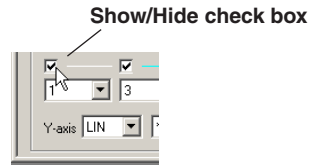

Selecting the Y-Axis (Current Magnitude) Scale

- **Selecting the Type of Y-Axis Scale**

Select **LIN** (linear) or **LOG** (logarithmic).



- **Selecting the Magnification**

When the type of scale is LIN, select ***100.0**, ***10.0**, ***5.0**, ***2.0**, ***1.0**, ***0.5**, or ***0.1**.

When the type of scale is LOG, select ***100.0**, ***10.0**, ***1.0**, or ***0.1**.

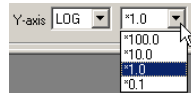

- **Enabling Percentage Display**

Select the **Percentage Display** check box. The Y-axis scale is displayed in percentages. The relative harmonic content of current of each order can be displayed on graphs with the specified fundamental current (fundamental current specified in advance when making Class C evaluation, see section 3.5) taken to be 100%.

Note

The Percentage Display check box becomes selectable under given conditions. The Percentage Display check box becomes selectable when the EUT is of Class C, and ratios are used to evaluate the limits.



Selecting the Time Zone

Use the scroll bar to set the time zone to be displayed. The harmonic current fluctuation graph of the specified time zone is displayed.

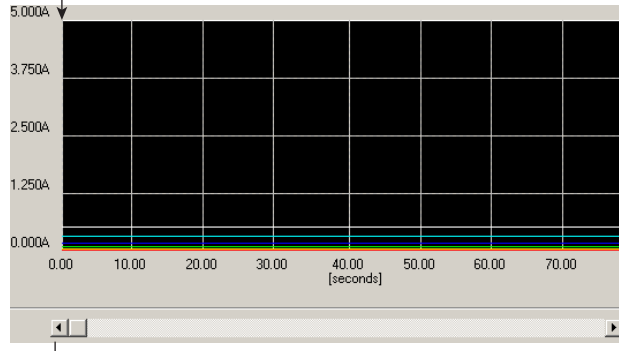
The left end position (time) corresponds to the cursor position (time, see page 4-4) of the Overall Evaluation Graph.



Scroll bar

Drag the  (slider) or click   to select the time zone you wish to display. The time zone of the graph changes in sync with the slider position.

Explanation

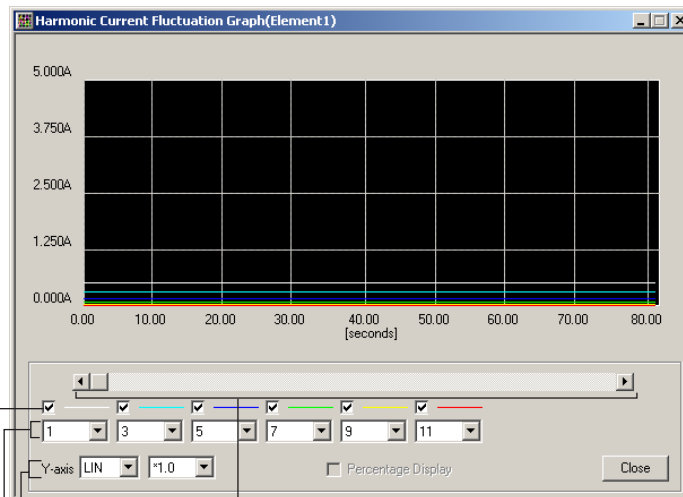

The harmonic current fluctuation over time can be displayed on graphs. The input element on which harmonic measurement is made varies depending on the wiring system configuration of the WT (see chapter 8) that you are using. The bar graph can be displayed for each input element of the WT.

Harmonic Current Fluctuation Graph Window



Select the Y-axis scale

Scroll bar

Drag the  (slider) or click   to select the time zone you wish to display. The time zone of the graph changes in sync with the slider position.

Order selection box

Show/Hide check box

4.4 Displaying the Bar Graph of the Harmonic Current Fluctuation

Selecting the Order

The maximum number of graph lines that can be displayed is 6. For each graph, you can select which order of harmonic current to be displayed.

Selectable range: 1 to 40 or THC

Selecting Show/Hide

You can select whether to show or hide each graph.

Selecting the Y-Axis (Current Magnitude) Scale

- **Type of Y-Axis Scale**

You can select LIN (linear) or LOG (logarithmic).

- **Selecting the Magnification**

When the type of scale is LIN, you can select *100.0, *10.0, *5.0, *2.0, *1.0, *0.5, or *0.1.

When the scale type is LOG, you can select *100.0, *10.0, *1.0, or *0.1.

- When set to *1.0, the maximum value of the Y-axis LIN scale is the value of the measurement range selected in the WT configuration (see chapter 8). The maximum value of the LOG scale is one digit above the measurement range, and is a value that is an integer power of 10.

- **Percentage Display**

If you select the Percentage Display check box, the Y-axis scale can be displayed in percentages. The change in the relative harmonic content of current of each order can be displayed on graphs with the specified fundamental current (fundamental current specified in advance when making Class C evaluation, see section 3.6) taken to be 100%.

- When the magnification of the Y-axis scale is *1.0, the maximum scale of Y-axis is 100.00%.
- The Percentage Display check box becomes selectable under given conditions. The Percentage Display check box becomes selectable when the EUT is of Class C, and ratios are used to evaluate the limits (see section 1.3).

Color

The colors of the 6 graphs are as follows:

White, turquoise, blue, bright green, yellow, and red.

* The names of the sample colors of Microsoft Word or Excel are used for the names of the colors.

Mutual Relationship between the Harmonic Current Change Graph and Measured Value Judging Graph (see section 4.1)

The left end position (time) of the Harmonic Current Change Graph corresponds to the cursor position (time, see page 4-4) of the Measured Value Judging Graph. If you move the cursor on the Measured Value Judging Graph, the time at the cursor position becomes the time at the left end of the Harmonic Current Change Graph.

4.5 Displaying the Voltage/Current Waveforms

Procedure

The input element on which harmonic measurement is made varies depending on the wiring system configuration of the WT (see chapter 8) that you are using. Below a procedure is given in which the wiring system of the WT3000 is set to single-phase two-wire (1P2W) and one input element is used.

The waveform data retrieved immediately before the measurement was stopped in Harmonic Measurement Mode (see section 3.4) is displayed as voltage or current waveform on the waveform graph.

Displaying Waveforms

From the **View** menu, point to **Wave Graph** then choose **Element1**. The Waveform Graph (Element 1) window opens. You can also choose **View > Wave Graph > Element1** from the toolbar.

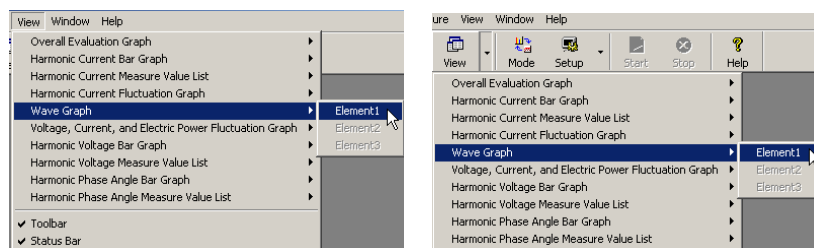

Display Example: Wave Graph (Element 1)

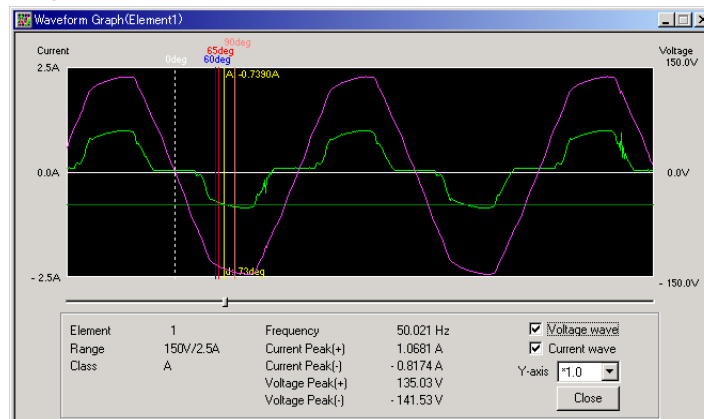

Showing/Hiding Waveforms

Use the show/hide check box to select whether to show or hide the waveform. The selection can be made for the voltage and current individually.

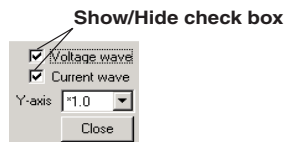

4.5 Displaying the Voltage/Current Waveforms

Selecting the Magnification of the Y-Axis (Voltage or Current Magnitude) Scale

Select a value from *100.0, *10.0, *5.0, *2.0, *1.0, *0.5, and*0.1.

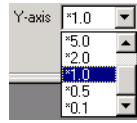

Displaying the Current Value and Phase Angle Using the Cursor

Drag the slider with the mouse to move the cursor. The current value and phase angle at the new cursor position are displayed.

The phase angle is the phase difference with respect to the first zero crossing of the voltage waveform as 0 degrees within the waveform display area.

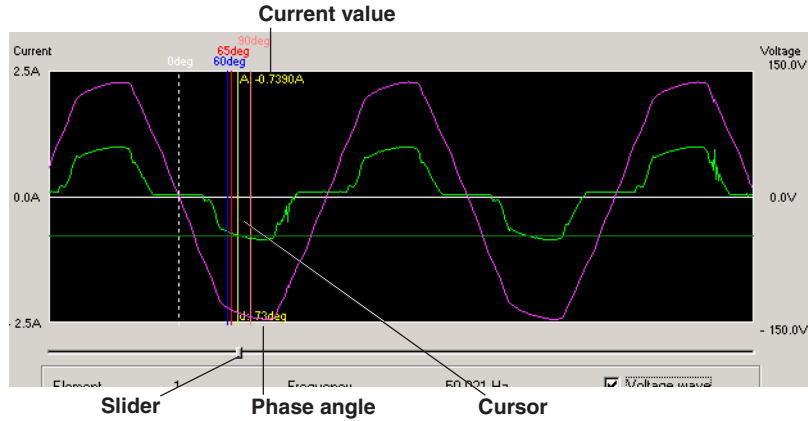

Explanation

The waveform data retrieved immediately before the measurement was stopped in Harmonic Measurement Mode (see section 3.4) is displayed as voltage or current waveform on the waveform graph. The bar graph can be displayed for each input element of the WT. The data is also different from the data displayed in Harmonic Monitor or Waveform Monitor Mode. When evaluating Class C equipment with active input power less than or equal to 25 W using the limits of the harmonics of order 3 and 5, view the waveform data here and check whether the relationship of the voltage and current waveforms is within the limits.

Waveform Graph

First zero crossing point of the voltage waveform

Indicates the position of the phase angles of 60, 65, and 90 degrees, which are used in the evaluation of Class C equipment with active input power less than or equal to 25 W.

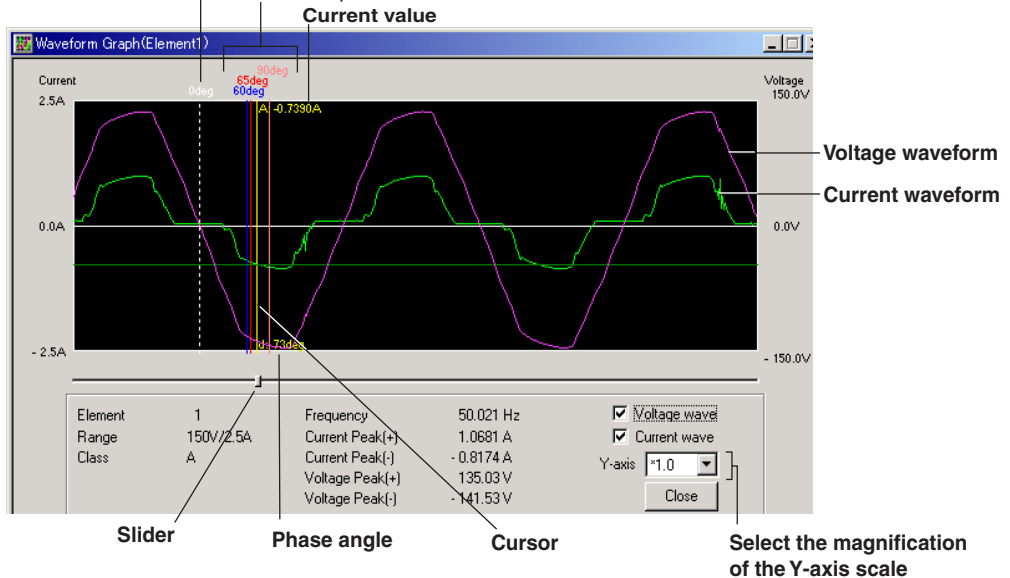

- **Element**
Number of the input element under evaluation. In this example, input element 1 is being displayed.
- **Range**
Measurement range selected in the WT configuration (see chapter 8).
- **Class**
Class of the applicable standard.
- **Frequency**
The average value of all frequencies (frequency of the fundamental signal of the PLL source) within the measurement time.
- **Current Peak (+)**
Maximum positive value of the current waveform displayed.
- **Current Peak (-)**
Maximum negative value of the current waveform displayed.
- **Voltage Peak (+)**
Maximum positive value of the voltage waveform displayed.
- **Voltage Peak (-)**
Maximum negative value of the voltage waveform displayed.

Selecting Show/Hide

You can select whether to show or hide the voltage and current individually.

Selecting the Magnification of the Y-Axis (Voltage or Current Magnitude) Scale

- The scale type is fixed to LIN (linear). LOG (logarithmic) scale is not supported.
- You can select the magnification from *100.0, *10.0, *5.0, *2.0, *1.0, *0.5, and *0.1.

Displaying the Current Value and Phase Angle Using the Cursor

When evaluating Class C equipment with active input power less than or equal to 25 W using the limits of the harmonics of order 3 and 5, you can check whether the relationship of the voltage and current waveforms is within the limits.

- You can display the current value and phase angle at the new cursor position.
- The phase angle is the phase difference with respect to the first zero crossing of the voltage waveform (0 degrees) within the waveform display area.
- Fixed vertical lines are displayed at the phase angles 60, 65, and 90 degrees used in the evaluation. You can check the evaluation conditions (see section 1.3) by viewing the fixed lines and the current waveform.

Note

If the PLL frequency differs from the voltage frequency being displayed, for the element, the display may be incorrect since the phase angle value is displayed according to the PLL frequency. Measurements should be taken only when the PLL frequency and voltage frequency are the same.

4.6 Displaying the Graph of Voltage, Current, and Power

Procedure

The input element on which harmonic measurement is made varies depending on the wiring system configuration of the WT (see chapter 8) that you are using. Below a procedure is given in which the wiring system of the WT3000 is set to single-phase two-wire (1P2W) and one input element is used.

Displaying the Voltage, Current, and Power Fluctuation Graph

From the **View** menu, point to **Voltage, Current, and Electric Power Fluctuation Graph**, and then choose **Element1**. The Voltage, Current, Electric Power Fluctuation Graph (Element 1) window opens. You can also choose **View > Voltage, Current, and Electric Power Fluctuation Graph > Element1** from the toolbar.

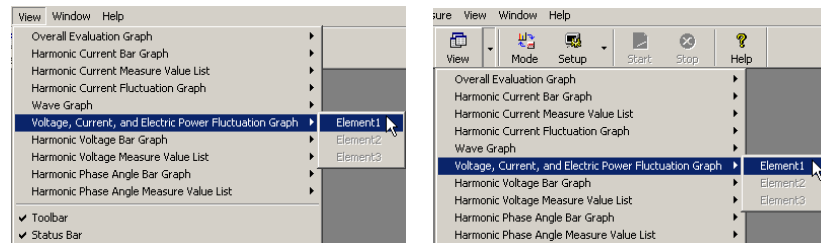

Display Example: Voltage, Current, and Electric Power Fluctuation Graph (Element 1)

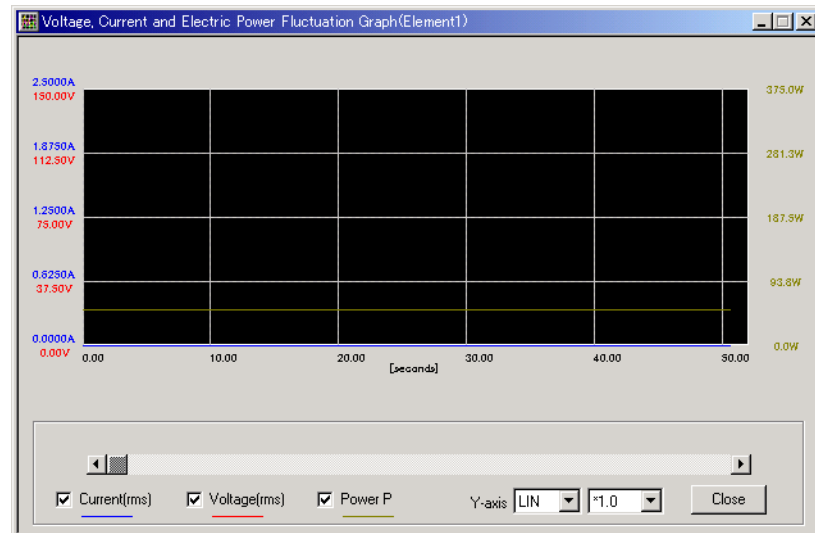

Showing/Hiding the Graph

Use the show/hide check box to select whether to show or hide the waveform. Selection can be made for voltage (rms), current (rms), and active power individually.



Selecting the Y-Axis (Current Magnitude) Scale

- **Selecting the Type of Y-Axis Scale**
Select **LIN** (linear) or **LOG** (logarithmic).



- **Selecting the Magnification**

When the type of scale is LIN, select ***100.0**, ***10.0**, ***5.0**, ***2.0**, ***1.0**, ***0.5**, or ***0.1**.
When the type of scale is LOG, select ***100.0**, ***10.0**, ***1.0**, or ***0.1**.

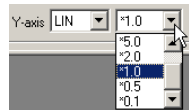



Selecting the Time Zone

Use the scroll bar to set the time zone to be displayed. The voltage, current, and electric power fluctuation graph of the specified time zone is displayed.

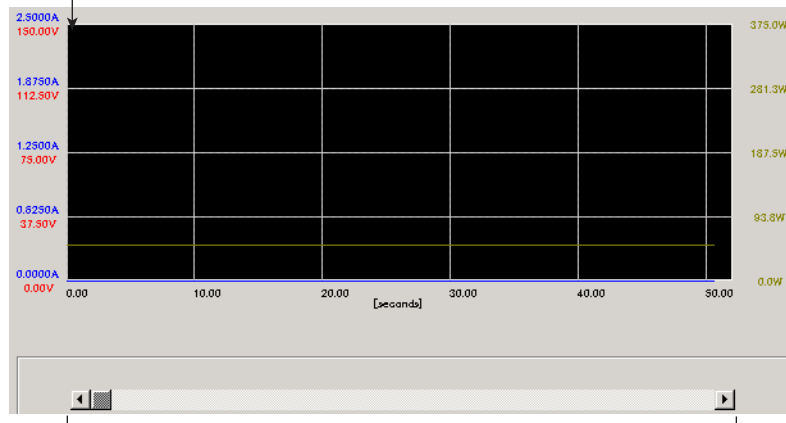
The left end position (time) corresponds to the cursor position (time, see page 4-4) of the Overall Evaluation Graph.



Scroll bar

Drag the  (slider) or click   to select the time zone you wish to display. The time zone of the graph changes in sync with the slider position.

4.6 Displaying the Graph of Voltage, Current, and Power

Explanation

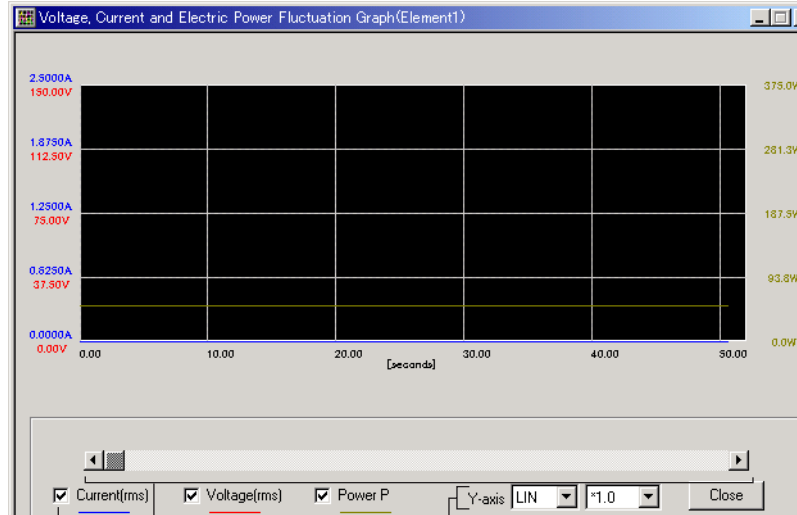

The fluctuation of the voltage, current, and power data over time can be displayed on graphs. The input element on which harmonic measurement is made varies depending on the wiring system configuration of the WT (see chapter 8) that you are using. The bar graph can be displayed for each input element of the WT.

Voltage, Current, and Electric Power Fluctuation Graph Window



Select the Y-axis scale

Scroll bar

Drag the  (slider) or clic   to select the time zone you wish to display. The time zone of the graph changes in sync with the slider position.

Show/Hide check box

Selecting Show/Hide

You can select whether to show or hide the voltage (rms), current (rms), and active power individually.

Selecting the Y-Axis (Current Magnitude) Scale

• Type of Y-Axis Scale

You can select LIN (linear) or LOG (logarithmic).

• Selecting the Magnification

When the type of scale is LIN, you can select *100.0, *10.0, *5.0, *2.0, *1.0, *0.5, or *0.1.

When the scale type is LOG, you can select *100.0, *10.0, *1.0, or *0.1.

- When set to *1.0, the maximum value of the Y-axis LIN scale is the value of the measurement range selected in the WT configuration (see chapter 8). The maximum value of the LOG scale is one digit above the measurement range, and is a value that is an integer power of 10.

Color

The colors of the voltage (rms), current (rms), and active power graphs are as follows:

■ blue: current (rms), ■ red: voltage (rms), ■ dark yellow: active power

* The names of the sample colors of Microsoft Word or Excel are used for the names of the colors.

Mutual Relationship between the Voltage, Current, and Electric Power Fluctuation Graph and Overall Evaluation Graph (See Section 4.1)

The left end position (time) of the Voltage, Current, and Electric Power Fluctuation Graph corresponds to the cursor position (time, see page 4-4) of the Overall Evaluation Graph. If you move the cursor on the Overall Evaluation Graph, the time at the cursor position becomes the time at the left end of the Voltage, Current, and Electric Power Fluctuation Graph.

4.7 Displaying the Bar Graph of the Harmonic Phase Angle

Procedure

The input element on which harmonic measurement is made varies depending on the wiring system configuration of the WT (see chapter 8) that you are using. Below a procedure is given in which the wiring system of the WT3000 is set to single-phase two-wire (1P2W) and one input element is used.

Displaying the Bar Graph of the Harmonic Phase Angle

From the **View** menu, point to **Harmonic Phase Angle Bar Graph** then choose **Element1**. The Harmonic Phase Angle Bar Graph (Element 1) window opens. You can also choose **View > Harmonic Phase Angle Bar Graph > Element1** from the toolbar.

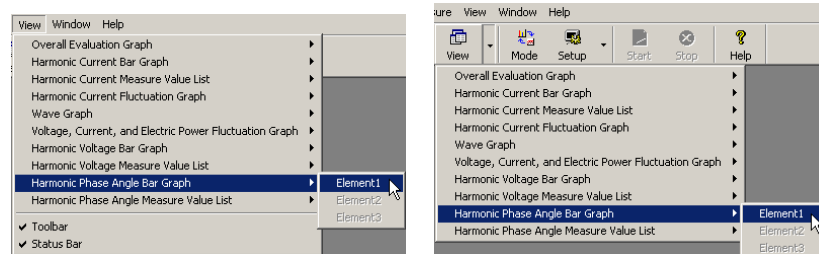

Display Example: Harmonic Phase Angle Value Bar Graph (Element 1)

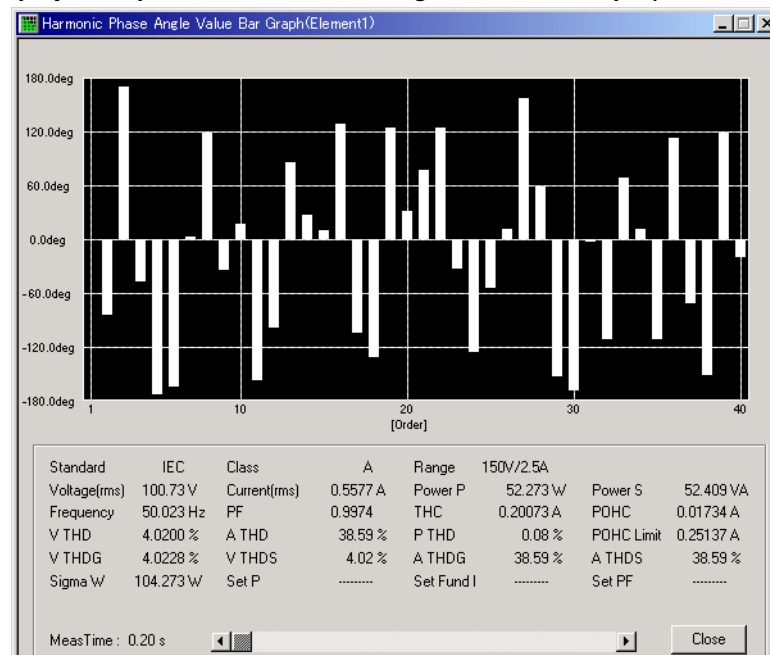



Selecting the Instantaneous Value

On the Harmonic Phase Angle Value Bar Graph window, you can use the scroll bar to select the instantaneous values to be displayed.



Scroll bar

Drag the  (slider) or click   to select the instantaneous value you wish to display. Meas Time changes in sync with the slider position.

Explanation

You can display the bar graph of the harmonic phase angle. The phase angle is not used to evaluate whether the limits of the applicable standard are met.

The input element on which harmonic measurement is made varies depending on the wiring system configuration of the WT (see chapter 8) that you are using. The bar graph can be displayed for each input element of the WT.

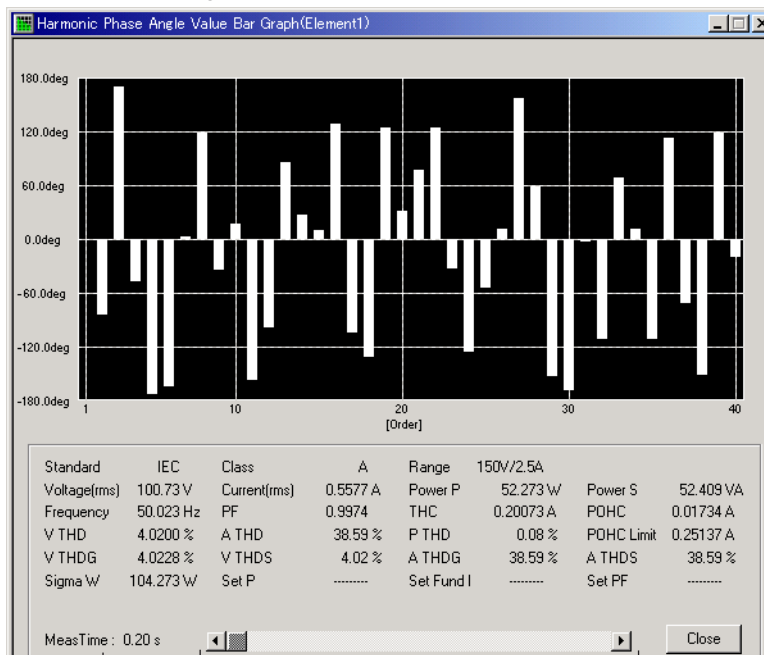
Harmonic Phase Angle Value Bar Graph Window**Scroll bar**

Drag the (slider) or click to select the instantaneous value you wish to display. Meas Time changes in sync with the slider position.

Meas Time

Indicates the time when the measured data was retrieved. This example indicates the time (0.2 s) when the first measured data was retrieved.

- Bar graphs of the phase angle of the harmonic current with respect to the fundamental current for each order can be displayed. However, the phase angle with respect to the fundamental voltage is displayed on the bar graph for the fundamental current.
 - When the harmonic phase is leading the fundamental current, a positive phase angle is indicated; when the harmonic phase is lagging the fundamental current, a negative phase angle is indicated.
 - When the fundamental current is leading the fundamental voltage, a negative phase angle is indicated; when the fundamental current is lagging the fundamental voltage, a positive phase angle is indicated.
- For a description of the items from Element to Set PF in the bar graph window, see the explanation in section 4.2, “Displaying the Bar Graph of Harmonic Current/Voltage” (page 4-8). However, because the phase angle does not need to be compared and evaluated against the limit, the Judgment item is not present.
- Bar graphs of phase angle are displayed in white.

Mutual Relationship of Graphs and Lists

See the explanation in section 4.2, “Displaying the Bar Graph of Harmonic Current/Voltage” (page 4-12).

4.8 Displaying the List of the Harmonic Phase Angle

Procedure

The input element on which harmonic measurement is made varies depending on the wiring system configuration of the WT (see chapter 8) that you are using. Below a procedure is given in which the wiring system of the WT3000 is set to single-phase two-wire (1P2W) and one input element is used.

Displaying the List of the Harmonic Phase Angle

From the **View** menu, point to **Harmonic Phase Angle Measure Value List** then choose **Element1**. The Harmonic Phase Angle Value List (Element 1) window opens. You can also choose **View > Harmonic Phase Angle Measure Value List > Element1** from the toolbar.

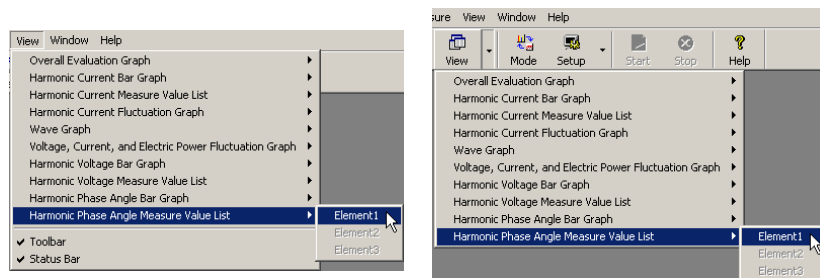

Display Example: Harmonic Phase Angle Measure Value List (Element 1)

Order	Measure [deg]
1	-4.08770
2	-83.6342
3	170.707
4	-47.4689
5	-173.054
6	-164.645
7	2.59589
8	118.593
9	-34.6318
10	17.2782
11	-157.684
12	-98.3698
13	85.8773
14	27.7886
15	10.0188
16	127.948
17	-104.366
18	-130.938
19	124.721
20	31.9072
21	76.7000
22	123.822
23	-33.3127
24	-125.198
25	-54.9865
26	11.7490
27	157.578
28	58.6677
29	-153.161
30	-168.572
31	-2.95922
32	-111.785
33	68.4043
34	11.1362
35	-111.518
36	112.394
37	-71.5644
38	-151.160

Element	1
Standard	IEC
Class	A
Range	150V/2.5A
Frequency	50.023 Hz
Voltage(rms)	100.73 V
Current(rms)	0.5577 A
Power P	52.273 W
Power S	52.409 VA
PF	0.9974
V THD	4.02 %
V THDS	4.02 %
V THDG	4.02 %
A THD	38.59 %
A THDS	38.59 %
A THDG	38.59 %
P THD	0.08 %
THC	0.20073 A
POHC	0.01734 A
POHC Limit	0.25137 A
Sigma W	104.273 W
Set P
Set Fund I
Set PF



MeasTime : 0.20 s

Selecting the Instantaneous Value

On the Harmonic Phase Angle Measure Value List window, you can use the scroll bar to select the instantaneous values to be displayed.



Scroll bar

Drag the  (slider) or click   to select the instantaneous value you wish to display. Meas Time changes in sync with the slider position.

Explanation



A List of the harmonic phase angles can be displayed. The phase angle is not used to evaluate whether the limits of the applicable standard are met.

The input element on which harmonic measurement is made varies depending on the wiring system configuration of the WT (see chapter 8) that you are using. The list can be displayed for each input element of the WT.

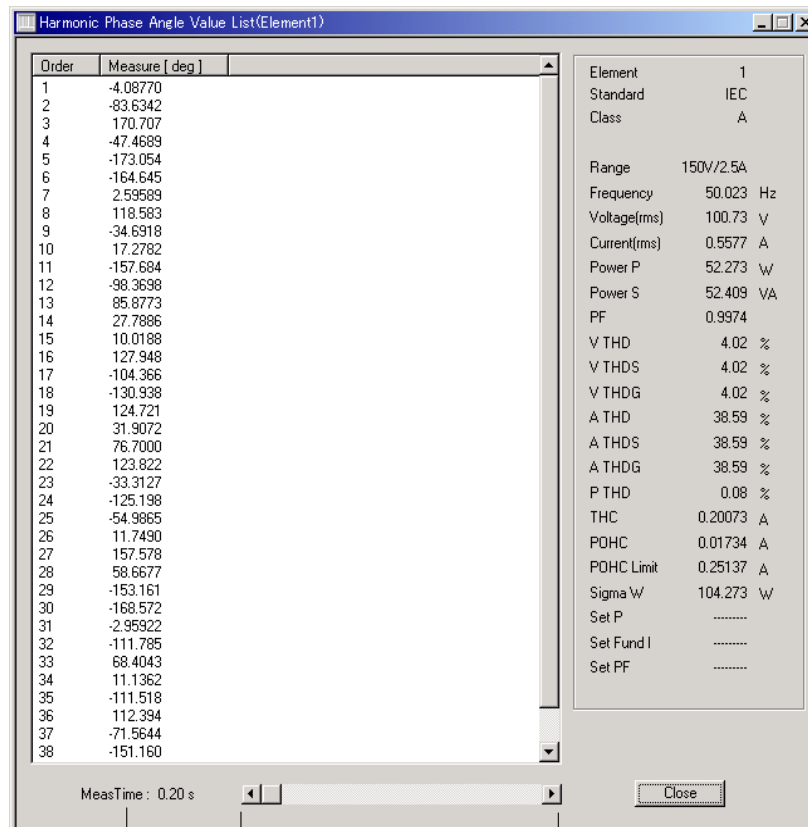
Harmonic Phase Angle Measure Value List Window



Scroll bar

Drag the  (slider) or click   to select the instantaneous value you wish to display. Meas Time changes in sync with the slider position.

Meas Time

Indicates the time when the measured data was retrieved. This example indicates the time (0.2 s) when the first measured data was retrieved.

4.8 Displaying the List of the Harmonic Phase Angle

- A list of the phase angle of the harmonic current with respect to the fundamental current for each order can be displayed. However, the phase angle with respect to the fundamental voltage is displayed in the list for the fundamental current.
- When the harmonic phase is leading the fundamental current, a positive phase angle is indicated; when the harmonic phase is lagging the fundamental current, a negative phase angle is indicated.
- When the fundamental current is leading the fundamental voltage, a negative phase angle is indicated; when the fundamental current is lagging the fundamental voltage, a positive phase angle is indicated.
- For a description of the items from Element to Set PF in the list window, see the explanation in section 4.2, "Displaying the Bar Graph of Harmonic Current/Voltage" (page 4-8). However, because the phase angle does not need to be compared and evaluated against the limit, the Judgment item is not present.

Mutual Relationship of Graphs and Lists

See the explanation in section 4.2, "Displaying the Bar Graph of Harmonic Current/Voltage" (page 4-12).

5.1 Monitoring Harmonics

Procedure

The input element on which harmonic monitor is performed varies depending on the wiring system configuration of the WT (see chapter 8) that you are using. Below a procedure is given in which the wiring system of the WT3000 is set to single-phase two-wire (1P2W) and one input element is used.

To select the Harmonic Monitor mode used to monitor the fluctuation of the harmonics while making measurements on the WT, you must set the communication mode to On-Line (see section 3.2).

Selecting the Harmonic Monitor Mode

- From the Setting menu, choose Measurement Mode. The Measurement mode setup dialog box opens. You can also click  on the toolbar. The Measureme

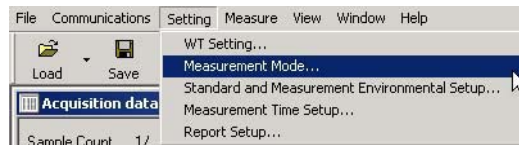

- Choose **Harmonic Monitor**. The Harmonic Monitor window appears.

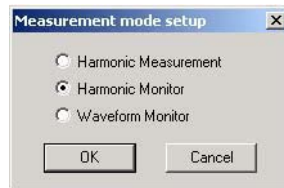

Display Example: Harmonic Monitor Window

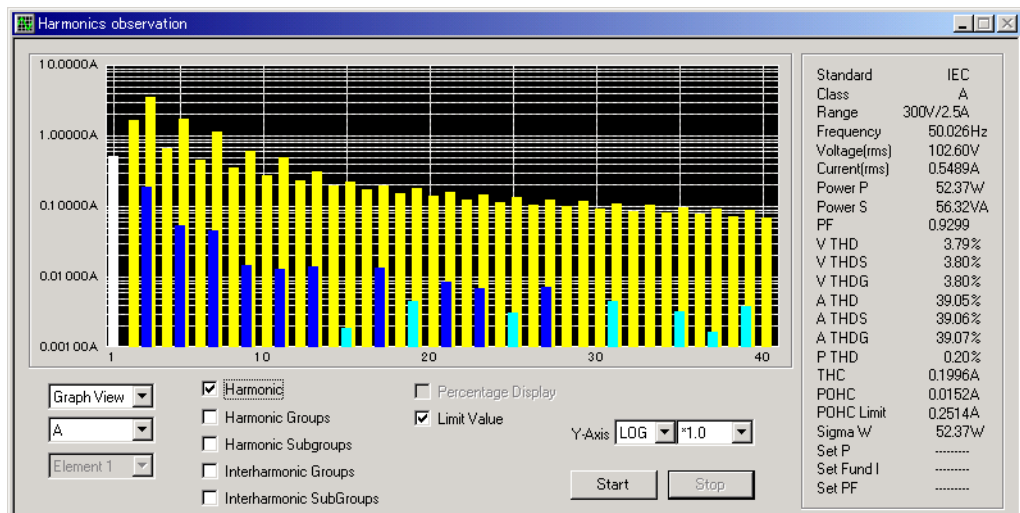

Note

When you switch the measurement mode, all the data retrieved and loaded up to that point are cleared. It is recommended that the data retrieved using Harmonic Measurement Mode be saved (see section 6.1) before changing the measurement mode.

5.1 Monitoring Harmonics

Starting/Stopping the Monitor Operation

- **Starting the Monitor Operation**
Click **Start**. The monitor operation starts.
- **Stopping the Monitor Operation**
Click **Stop**. The monitor operation stops.

Selecting the Monitored Contents

- **Selecting Bar or List**
Select **Graph View** (bar graph) or **List View** (list).



- **Selecting Current, Voltage, or Phase Angle**
Select **A** (current), **V** (voltage), or **Deg** (phase angle).



- **Selecting the Input Element**
Select the input element to be monitored.
The input element on which harmonic monitor is performed varies depending on the wiring system configuration of the WT (see chapter 8) that you are using.



- **Selecting the Type of Y-Axis Scale**
Select **LIN** (linear) or **LOG** (logarithmic).



- **Selecting the Magnification of the Y-Axis Scale**
When the type of scale is LIN, select ***100.0**, ***10.0**, ***5.0**, ***2.0**, ***1.0**, ***0.5**, or ***0.1**.
When the type of scale is LOG, select ***100.0**, ***10.0**, ***1.0**, or ***0.1**.

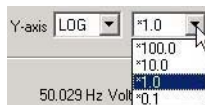

• **Setting the Y-Axis Scale to Percentage Display**

Select the **Percentage Display** check box. The Y-axis scale is displayed in percentages. The relative harmonic content of current of each order can be displayed on graphs with the specified fundamental current (fundamental current specified in advance when making Class C evaluation, see section 3.5) taken to be 100%.

Note

The Percentage Display check box becomes selectable under given conditions. The Percentage Display check box becomes selectable when the EUT is of Class C, and ratios are used to evaluate the limits.

• **Displaying the Limits**

Select the **Limit Value** check box. The limits specified in the applicable standard are displayed using yellow bars for each order.

The operation of the limit display is selectable only when the monitored item is current.

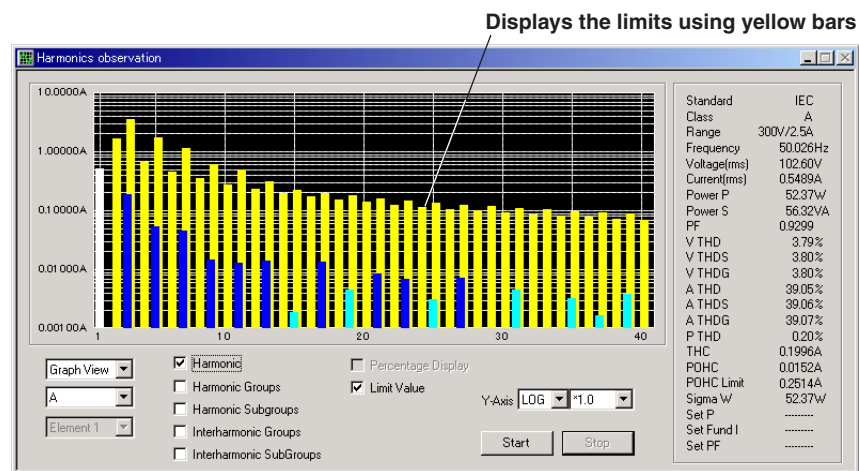

• **Displaying the Harmonic, Harmonic Group, and Harmonic Subgroup**

Select the **Harmonic**, **Harmonic Groups**, and **Harmonic Subgroups** check boxes. The measured value of each measurement item is shown using a bar graph.

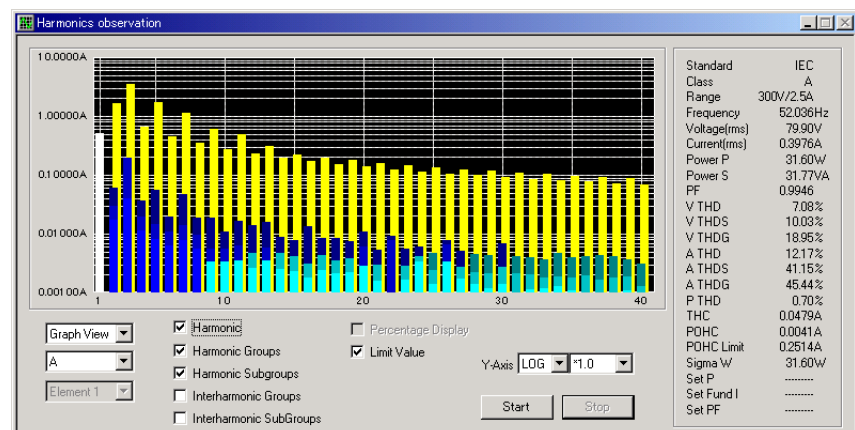

5.1 Monitoring Harmonics

- **Displaying the Interharmonic Group and Interharmonic Subgroup**
Select the **Interharmonic Groups** and **Harmonic Subgroups** check boxes. The measured value of each measurement item is shown using a bar graph.

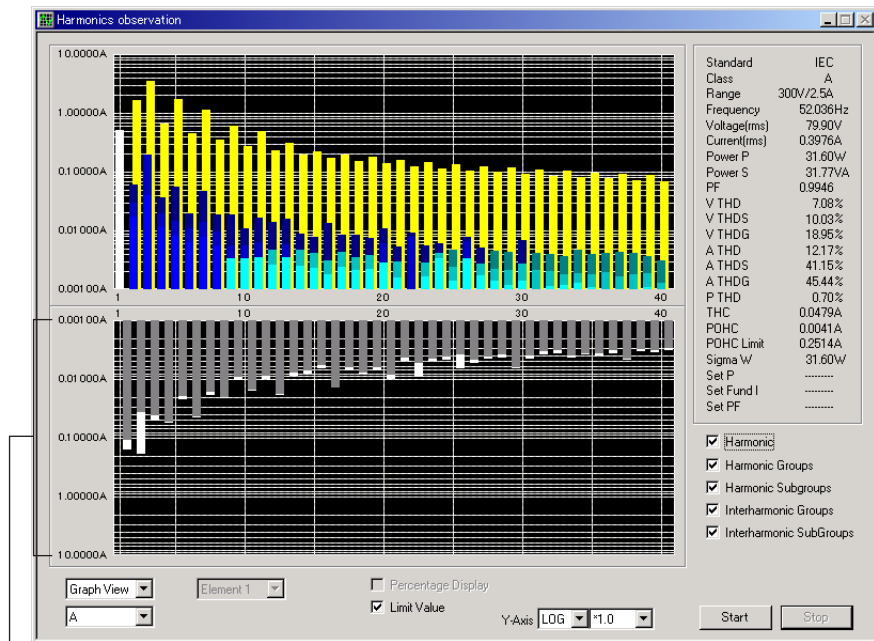

Clear the interharmonic group and interharmonic subgroup displays

Explanation

The Harmonic Monitor mode is selectable only when in On-Line mode. Harmonic fluctuation can be monitored on bar graphs and numerical lists while making harmonic measurements on the WT. This mode is used to monitor the conditions of the harmonics and does not evaluate against the standard as in Harmonic Measurement Mode. When the next measured data is retrieved, the previous measured data is updated and does not remain.

The input element on which harmonic monitor is performed varies depending on the wiring system configuration of the WT (see chapter 8) that you are using. The harmonics can be monitored for each input element of WT.

Harmonic Monitor Window (Bar Graph)

The figure below shows a bar graph example.

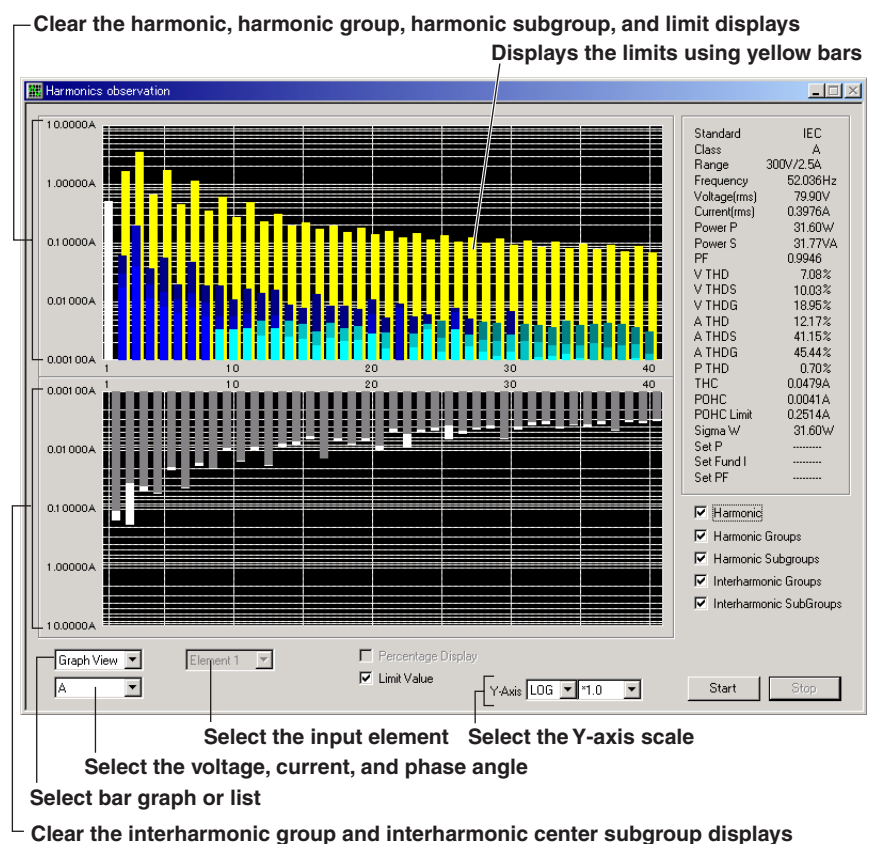

- You can monitor the bar graph or list of the voltage, current, or phase angle for each order.
 - When monitoring the current, the limits of the applicable standard can be displayed. When monitoring the voltage or phase angle, the limits are not displayed, because the voltage or phase angle does not need to be compared against the limits.
 - The concept of the phase angle reference is the same as the explanation given in section 4.7, "Displaying the Bar Graph of the Harmonic Phase Angle" (page 4-31).
- For a description of the items from Class to Set PF in the window, see the explanation in section 4.2, "Displaying the Bar Graph of Harmonic Current/Voltage" (page 4-8). However, Standard, Judgment, and Element items are not present.

Color of Bars

See the explanation in section 4.2, “Displaying the Bar Graph of Harmonic Current/ Voltage” (page 4-12). Bright green is not available.

- **Color of the Harmonic Group and Harmonic Subgroup of Current**

The harmonic, harmonic group, and harmonic subgroup are superimposed on the bar graph.

- **When the Measured Values Are within the Limit**

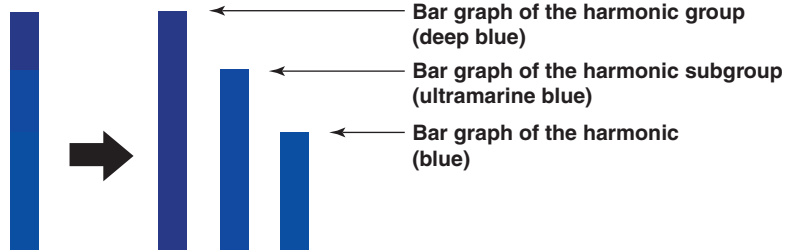

- **When Evaluation Is Not Made Because the Measured Data Is Less than the Larger of the Two Values, 0.6% of the Mean Rms Current and 5 mA**

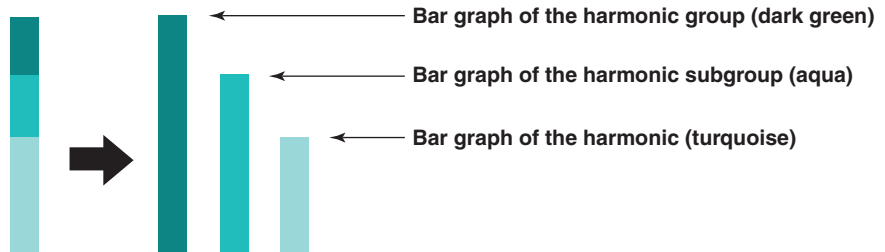

- **Color of the Harmonic Group and Harmonic Subgroup of Voltage**

The harmonic, harmonic group, and harmonic subgroup are displayed as shown below. There is no need to compare with the limit to make evaluations.

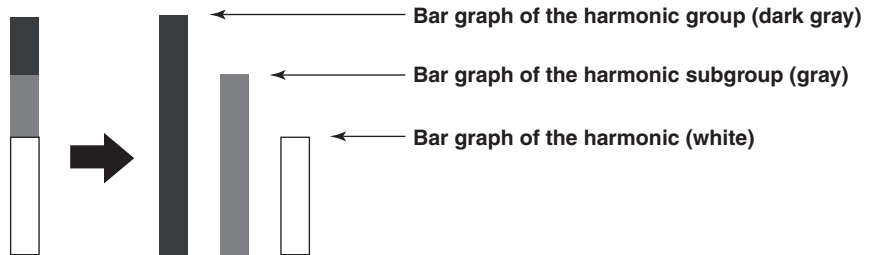

- **Color of the Interharmonic Group and Interharmonic Center Subgroup**

The interharmonic group and interharmonic center subgroup are displayed as shown below. There is no need to compare with the limit to make evaluations.

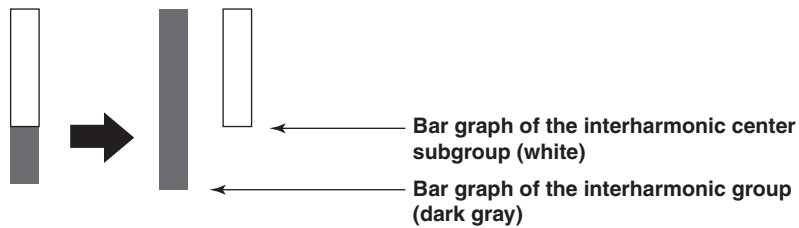

Color of Phase Angles

Bar graphs of phase angle are displayed in white. The values displayed in the list are black.

Displaying the Limits

Comparison and evaluation are not made against the limits in Harmonic Monitor mode. The limits specified by the applicable standard are displayed for reference. Since the harmonic data monitored in the Harmonic Monitor mode is an instantaneous value, the values (list) and yellow bars (bar graph) of the limits are 1.5 times the actual limits.

- If the Limit Value check box is selected, the limits are displayed using values or yellow bars for each order.
- The limits are displayed only for harmonic current.
- When limits are specified by the relative harmonic content of order 3 and 5 such as the limits for Class C equipment with active input power less than or equal to 25 W, bars of magnitude corresponding to the current values converted from the relative harmonic content of order 3 and 5 with the fundamental current specified in advance (see section 3.6) taken to be 100% are displayed.

Selecting the Y-Axis (Current Magnitude) Scale

- **Type of Y-Axis Scale**
You can select LIN (linear) or LOG (logarithmic).
- **Selecting the Magnification**
When the type of scale is LIN, you can select *100.0, *10.0, *5.0, *2.0, *1.0, *0.5, or *0.1.
When the scale type is LOG, you can select *100.0, *10.0, *1.0, or *0.1.
 - When set to *1.0, the maximum value of the Y-axis LIN scale is the value of the measurement range selected in the WT configuration (see chapter 8). The maximum value of the LOG scale is one digit above the measurement range, and is a value that is an integer power of 10.
- **Percentage Display**
If you select the Percentage Display check box, the Y-axis scale, THC, and POHC can be displayed in percentages. The relative harmonic content of current of each order can be displayed on bar graphs or lists with the specified fundamental current (fundamental current specified in advance when making Class C evaluation, see section 3.6) taken to be 100%.
 - When the magnification of the Y-axis scale is *1.0, the maximum scale of Y-axis is 100.00%.
 - The Percentage Display check box becomes selectable under given conditions. The Percentage Display check box becomes selectable when the EUT is of Class C, and ratios are used to evaluate the limits (see section 1.3).
 - The percentage display is applied only to harmonic current.
 - When limits are specified by the relative harmonic content of order 3 and 5 such as the limits for Class C equipment with active input power less than or equal to 25 W, bars corresponding to the magnitude of the values are displayed on the bar graph or the values are displayed in the list.

5.1 Monitoring Harmonics

Harmonic Monitor Window (List)

Harmonics
Harmonic group
Harmonic subgroup
Interharmonic group
Interharmonic center subgroup

Order	Measure [A]	MeasureG [A]	MeasureSG [A]	MeasureG [A]	MeasureSG [A]	Limit [A]
1	0.3947	0.5029	0.4809	0.1608	0.1091	
2	0.0169	0.0602	0.0293	0.1901	0.0367	1.6200
3	0.0393	0.1972	0.1918	0.0510	0.0422	3.4500
4	0.0113	0.0369	0.0196	0.0558	0.0541	0.6450
5	0.0082	0.0546	0.0143	0.0217	0.0192	1.7100
6	0.0063	0.0197	0.0108	0.0451	0.0437	0.4500
7	0.0077	0.0464	0.0142	0.0187	0.0164	1.1550
8	0.0055	0.0187	0.0096	0.0211	0.0202	0.3450
9	0.0034	0.0134	0.0055	0.0104	0.0092	0.6000
10	0.0033	0.0109	0.0057	0.0160	0.0153	0.2750
11	0.0036	0.0164	0.0062	0.0098	0.0087	0.4950
12	0.0027	0.0141	0.0047	0.0185	0.0180	0.2300
13	0.0034	0.0158	0.0057	0.0089	0.0079	0.3150
14	0.0025	0.0089	0.0046	0.0081	0.0073	0.1971
15	0.0023	0.0076	0.0041	0.0065	0.0058	0.2250
16	0.0018	0.0134	0.0031	0.0142	0.0138	0.1725
17	0.0024	0.0086	0.0043	0.0071	0.0064	0.1985
18	0.0022	0.0084	0.0036	0.0083	0.0078	0.1533
19	0.0022	0.0074	0.0037	0.0070	0.0062	0.1776
20	0.0028	0.0108	0.0060	0.0098	0.0084	0.1380
21	0.0016	0.0054	0.0029	0.0048	0.0043	0.1607
22	0.0007	0.0091	0.0076	0.0093	0.0052	0.1295
23	0.0016	0.0055	0.0029	0.0050	0.0045	0.1467
24	0.0033	0.0060	0.0041	0.0048	0.0042	0.1150
25	0.0014	0.0047	0.0024	0.0066	0.0037	0.1350
26	0.0034	0.0079	0.0067	0.0054	0.0047	0.1062
27	0.0017	0.0062	0.0027	0.0046	0.0042	0.1250
28	0.0014	0.0046	0.0022	0.0043	0.0039	0.0986
29	0.0012	0.0043	0.0022	0.0066	0.0062	0.1164
30	0.0014	0.0069	0.0028	0.0045	0.0039	0.0920
31	0.0010	0.0042	0.0022	0.0039	0.0034	0.1089
32	0.0012	0.0039	0.0021	0.0036	0.0033	0.0862
33	0.0012	0.0036	0.0018	0.0043	0.0040	0.1023

Standard IEC
 Class A
 Range 300V/2.5A
 Frequency 52.036Hz
 Voltage(rms) 79.90V
 Current(rms) 0.3976A
 Power P 31.60W
 Power S 31.77VA
 PF 0.9946
 V THD 7.08%
 V THDS 10.03%
 V THDG 18.95%
 A THD 12.17%
 A THDS 41.15%
 A THDG 45.44%
 P THD 0.70%
 THC 0.0479A
 PDHC 0.0041A
 PDHC Limit 0.2514A
 Sigma W 31.60W
 Set P
 Set Fund I
 Set PF

Harmonic
 Harmonic Groups
 Harmonic Subgroups
 Interharmonic Groups
 Interharmonic SubGroups

List View | Element 1 | Percentage Display
 A | Start | Stop

Color of Measured Values Displayed in the List

See the explanation in section 4.3, "List Display of Harmonic Current/Voltage" (page4-18). Bright green is not available.

5.2 Monitoring Waveforms

Procedure

The input element on which waveform monitor is performed varies depending on the wiring system configuration of the WT (see chapter 8) that you are using. Below a procedure is given in which the wiring system of the WT3000 is set to single-phase two-wire (1P2W) and one input element is used.

To select the Waveform Monitor mode used to monitor the waveforms while making measurements on the WT, you must set the communication mode to On-Line (see section 3.2).

Selecting the Waveform Monitor Mode

1. From the Setting menu, choose Measurement Mode. The Measurement mode setup dialog box opens. You can also click  on the toolbar.

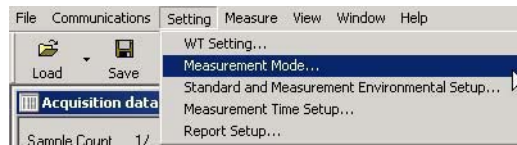

2. Choose **Waveform Monitor**. The Waveform Monitor window opens.

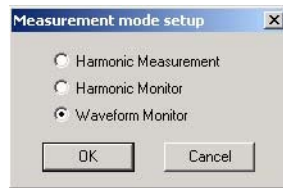

Display Example: Waveform Monitor Window

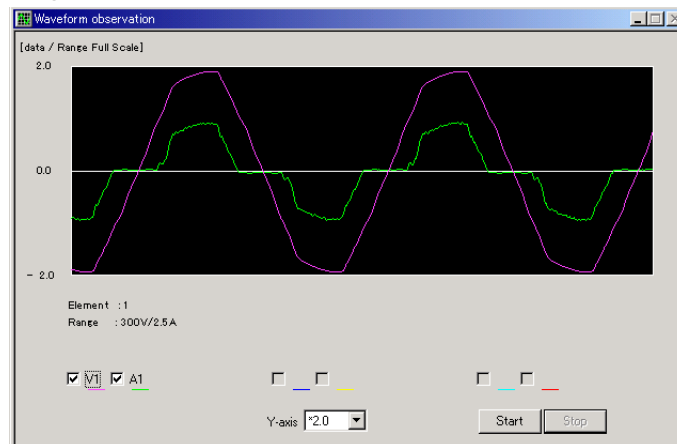

Note

When you switch the measurement mode, all the data retrieved and loaded up to that point is cleared. It is recommended that the data retrieved using Harmonic Measurement Mode be saved (see section 6.1) before changing the measurement mode.

5.2 Monitoring Waveforms

Starting/Stopping the Monitor Operation

- **Starting the Monitor Operation**

Click **Start**. The monitor operation starts.

- **Stopping the Monitor Operation**

Click **Stop**. The monitor operation stops.

Showing/Hiding Waveforms

Use the show/hide check box to select whether to show or hide the waveform.

The selection can be made for the voltage and current individually.

Show/Hide check box



Voltage (V1) and
current (A1) of input
element 1

Voltage (V2) and
current (A2) of input
element 2

Voltage (V3) and
current (A3) of input
element 3

Selecting the Magnification of the Y-Axis (Voltage or Current Magnitude) Scale

Select a value from *100.0, *10.0, *5.0, *2.0, *1.0, *0.5, and*0.1.

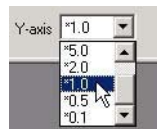

Explanation

The Waveform Monitor mode is selectable only when in On-Line mode. The measured waveform can be monitored while making harmonic measurements on the WT. This mode is used to monitor the conditions of the waveform and does not evaluate against the standard as in Harmonic Measurement Mode. When the next waveform data is retrieved, the previous waveform data is updated and does not remain.

The input element on which waveform monitor is performed varies depending on the wiring system configuration of the WT (see chapter 8) that you are using. The waveforms of relevant input elements can be monitored simultaneously.

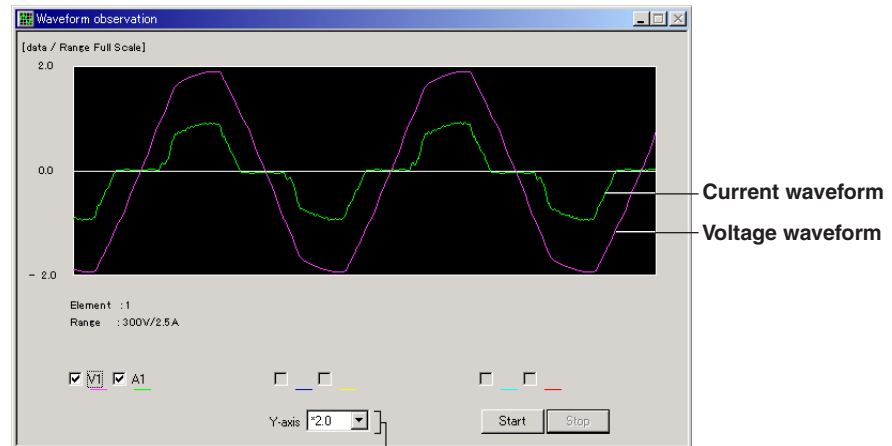
Waveform Monitor Window

Select the magnification of the Y-axis scale

- **Element**
The number of the input element under observation. In this example, input element 1 is under observation.
- **Range**
Measurement range selected in the WT configuration (see chapter 8).

Selecting Show/Hide

You can select whether to show or hide the voltage and current individually for each input element.

Selecting the Magnification of the Y-Axis (Voltage or Current Magnitude) Scale

- The scale type is fixed to LIN (linear). LOG (logarithmic) scale is not supported.
- You can select the magnification from *100.0, *10.0, *5.0, *2.0, *1.0, *0.5, and *0.1.
- Waveforms are displayed with the measurement range selected in the WT Setting (chapter 8) is taken to be the maximum value (1.0) of the Y-axis scale

Color

The colors below are assigned in ascending order of input element number for which the waveform is monitored. For example, the colors of voltage/current waveforms are assigned as follows when the waveforms a wiring unit consisting of input elements 1, 2, and 3 are monitored:

Element	Voltage	Current
Input element 1	■ Pink	■ Bright green
Input element 2	■ Blue	■ Yellow
Input element 3	■ Turquoise	■ Red

* The names of the sample colors of Microsoft Word or Excel are used for the names of the colors.

6.1 Saving Setup Information, Measured Data, and Waveform Data

Procedure

Note

- Setup information, measured data, or waveform data cannot be saved when the measurement mode is set to Harmonic Monitor or Waveform Monitor or when no setup information, measured data, or waveform data is present.
- Setup information, measured data, and waveform data cannot be saved while measurement is in progress.

Saving Setup Information

1. From the **File** menu, point to **Save**, then choose **Save Setup Information**. The Save As dialog box opens. You can also select **Save Setup Information** from the **Save** icon on the toolbar.

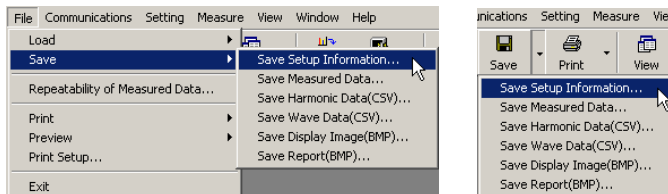

2. After setting the **Save in** box, enter the name of the file you wish to save in the **File name** entry box.
3. Click **Save**. The setup information is saved.

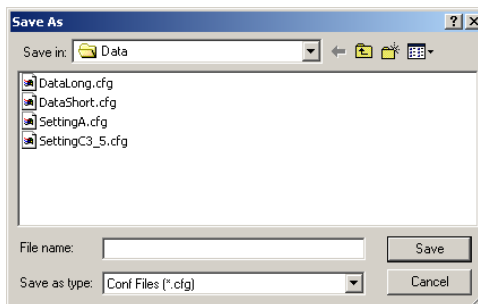

6.1 Saving Setup Information, Measured Data, and Waveform Data

Saving Measured Data, Waveform Data, or Setup Information

When the measurement mode is set to Harmonic Measurement and the measured data or waveform data has been retrieved (or loaded), the measured data or waveform data can be saved.

1. From the **File** menu, point to **Save**, then choose **Save Measure Data**. The Save As dialog box opens. You can also select **Save Measure Data** from the **Save** icon on the toolbar.

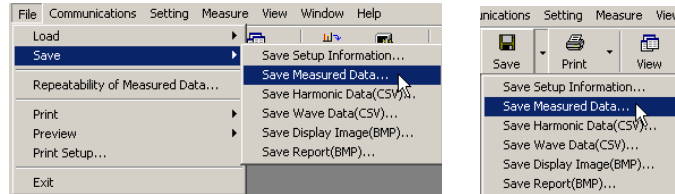

2. After setting the **Save in** box, enter the name of the file you wish to save in the **File name** entry box.
3. Click **Save**. Measured data, waveform data, or setup information is saved.

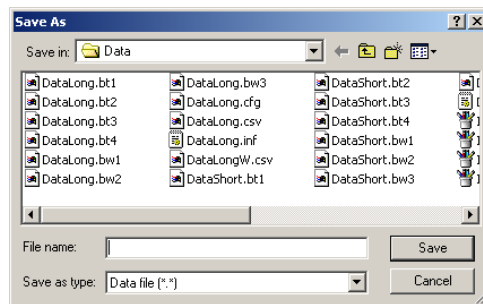

Explanation**Saving Setup Information**

Various setup information configured using the software including the measurement mode (see section 3.4), standard and measurement environment settings (see section 3.5), measurement time (see section 3.6), display settings (chapters 4 and 5), title/comment of reports (see section 7.2) can be saved to a file.

File Name, Extension, and Data Size

The file name can be any legal file name as defined by the PC that you are using.

- Extension: .cfg
- Data size: Approx. 3 KB

Saving Measured Data, Waveform Data, or Setup Information

- The harmonic measurement data or waveform data retrieved from the WT in Harmonic Measurement mode into the PC using the software can be saved to a file. In this case, the harmonic measurement conditions of the WT specified using the software and setup information described above are also saved.
- When the measurement mode is set to Harmonic Measurement and the measured data or waveform data has been retrieved (or loaded), the measured data or waveform data can be saved.

File Name, Extension, and Data Size

- The file name can be any legal file name as defined by the PC that you are using.
- When the save operation is executed, all the files with the extensions shown in the following table are created using the same file name.
- The extensions .bt1 to .bt3 and .bw1 to .bw3 below are assigned in ascending order of input element number for which the harmonics are measured. For example, the file name extension and measured data correspond as shown below when the harmonics of a wiring unit consisting of input elements 1, 2, and 3 are measured.
- Even when only the measured data or waveform data of input element 1 is present, the files with extensions .bt1 to 4, .bw1 to 3, .inf, and .cfg are created. However, in such cases, data corresponding to zero is saved in the .bt2 to 4 and .bw2 to 3 files.

Data Type	Extension	Data Size (Bytes)
Measured data of input element 1	.bt1	Approx. 400 K (when the measurement time is 2 min. 30 s)
Measured data of input element 2	.bt2	Approx. 400 K (when the measurement time is 2 min. 30 s)
Measured data of input element 3	.bt3	Approx. 400 K (when the measurement time is 2 min. 30 s)
Measured data common to all input elements	.bt4	Approx. 18 K (when the measurement time is 2 min. 30 s)
Waveform data of input element 1 Data displayed as voltage/current waveforms (see section 4.5).	.bw1	Approx. 18K
Waveform data of input element 2 Data displayed as voltage/current waveforms.	.bw2	Approx. 18K
Waveform data of input element 3 Data displayed as voltage/current waveforms.	.bw3	Approx. 18K
Harmonic measurement conditions of the WT For details on the measurement conditions, see chapter 8.	.inf	Approx. 2K
Setup information of specifications, evaluation, etc. Same data as those described in "Saving Setup Information" above.	.cfg	Approx. 3K

6.2 Loading Setup Information, Measured Data, and Waveform Data

Procedure

Note

- Setup information, measured data, and waveform data cannot be loaded when the measurement mode is set to Harmonic Monitor or Waveform Monitor.
- If an error occurs while loading the setup information, the settings are reset to their default values.
- If an error occurs while loading setup information, measured data, or waveform data, the data may not be loaded properly. Check the file name and extension, and load the data again.
- Setup information, measured data, and waveform data cannot be loaded while measurement is in progress.

Loading Setup Information

1. From the **File** menu, point to **Load** then choose **Load Setup Information**. The Open dialog box opens. You can also select **Load Setup Information** from the **Load** icon on the toolbar.

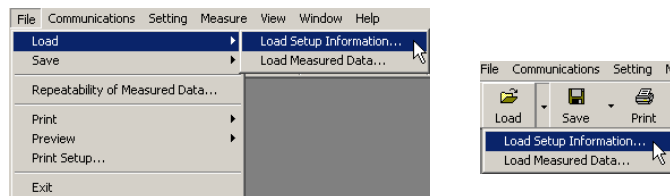

2. Select a file name and click **Open**. The setup information of the selected file is loaded.

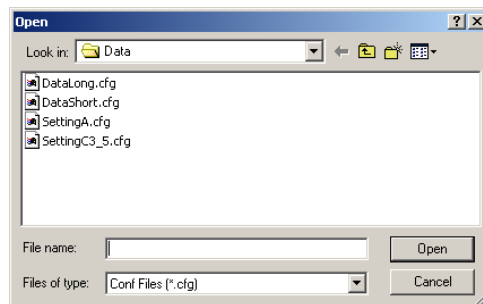

Loading Measured Data, Waveform Data, and Setup Information

Measured data, waveform data, and setup information can be loaded when the measurement mode is set to Harmonic Measurement.

1. From the **File** menu, point to **Load**, and then choose **Load Measure Data**. The Open dialog box opens. You can also select **Load Measure Data** from the **Load** icon on the toolbar.

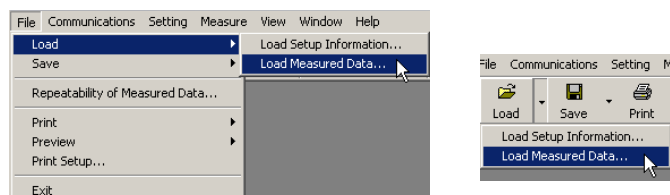

2. Select a file name and click **Open**. The measured data, waveform data, or setup information of the selected file is loaded.

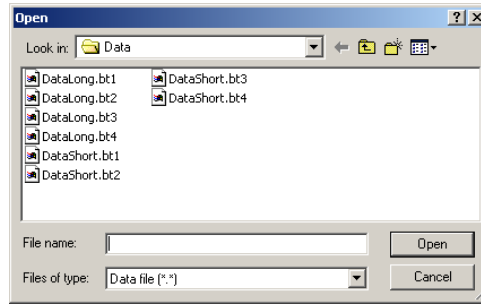

Explanation

Loading Setup Information

The setup information saved in section 6.1 can be loaded.

- The extension of the loaded file is .cfg.
- The contents of the setup information are as follows:
 - Measurement mode (see section 3.4).
 - Standard and measurement environment settings (see section 3.5).
The measurement data retrieved from the WT or loaded from a file can be evaluated using the loaded evaluation conditions.
 - Measurement time (see section 3.6).
 - Display settings (chapters 4 and 5).
 - Title/Comment of Reports (see section 7.2).

Reports of measurement data retrieved from the WT or loaded from a file can be saved or printed by attaching the loaded title or comment. For the saving and printing procedure, see chapter 7.

Loading Measured Data, Waveform Data, and Setup Information

- The measurement data, waveform data, and setup information saved in section 6.1 can be loaded.
- Measured data can be loaded when the measurement mode is set to Harmonic Measurement.
- When one of the files with .bt1, .bt2, .bt3, and .bt4 extension is selected in the Open dialog box and loaded, the data of all the files with the same file name in the same directory is loaded. See the table on the next page.

6.2 Loading Setup Information, Measured Data, and Waveform Data

Data Type	Extension
WT3000 Measured data on the left side of the acquisition data window	.bt1
Measured data in the center of the acquisition data window	.bt2
Measured data on the right of the acquisition data window	.bt3
Measured data common to all input elements	.bt4
Waveform data on the left side of the acquisition data window	.bw1
Waveform data in the center of the acquisition data window	.bw2
Waveform data on the right side of the acquisition data window	.bw3
Harmonic measurement conditions of the WT	.inf
<ul style="list-style-type: none"> If the communication mode is On-Line, the harmonic measurement conditions of the loaded file are applied to "WT Setting" (chapter 8) of the software and transmitted to the WT. If the transmitted harmonic measurement conditions do not match the configuration of the WT, an error message appears. Check the configuration of the connected WT. If the communication mode is Off-Line, the harmonic measurement conditions of the loaded file are applied to "WT Setting" of the software, but not transmitted to the WT. If the mode is switched from Off-Line to On-Line, the harmonic measurement conditions is loaded from the WT into the software. 	
Setup information of specifications, evaluation, etc.	.cfg
Same data as those described in "Setup Information" above.	

Order	Element 1			Element 2			Element 3		
	Voltage	Current	Phase	Voltage	Current	Phase	Voltage	Current	Phase
1	100.646 V	0.520 A	- 4.087	100.624 V	0.518 A	- 4.079	100.617 V	0.000 A	0.000
2	0.060 V	0.001 A	- 83.634	0.059 V	0.001 A	- 85.536	0.060 V	0.000 A	0.000
3	1.353 V	0.183 A	- 170.707	1.342 V	0.182 A	- 170.722	1.344 V	0.000 A	0.000
4	0.034 V	0.001 A	- 47.468	0.034 V	0.001 A	- 46.571	0.034 V	0.000 A	0.000
5	3.281 V	0.059 A	- 173.054	3.275 V	0.059 A	- 173.303	3.272 V	0.000 A	0.000
6	0.032 V	0.000 A	- 164.645	0.032 V	0.000 A	- 139.208	0.033 V	0.000 A	0.000
7	1.322 V	0.046 A	- 2.596	1.321 V	0.046 A	- 2.511	1.333 V	0.000 A	0.000
8	0.019 V	0.000 A	- 118.583	0.019 V	0.000 A	- 104.008	0.019 V	0.000 A	0.000
9	0.257 V	0.016 A	- 34.691	0.262 V	0.016 A	- 34.183	0.257 V	0.000 A	0.000
10	0.022 V	0.000 A	- 17.278	0.022 V	0.000 A	- 67.502	0.022 V	0.000 A	0.000
11	1.166 V	0.014 A	- 157.684	1.174 V	0.014 A	- 158.088	1.174 V	0.000 A	0.000
12	0.024 V	0.000 A	- 98.369	0.025 V	0.000 A	- 112.969	0.025 V	0.000 A	0.000
13	0.421 V	0.013 A	- 85.877	0.426 V	0.013 A	- 85.864	0.429 V	0.000 A	0.000
14	0.018 V	0.001 A	- 27.789	0.019 V	0.001 A	- 94.298	0.019 V	0.000 A	0.000
15	0.230 V	0.004 A	- 10.019	0.232 V	0.004 A	- 9.657	0.232 V	0.000 A	0.000
16	0.024 V	0.000 A	- 127.948	0.024 V	0.000 A	- 33.746	0.024 V	0.000 A	0.000
17	0.455 V	0.013 A	- 104.366	0.457 V	0.013 A	- 104.679	0.457 V	0.000 A	0.000
18	0.022 V	0.001 A	- 130.938	0.022 V	0.001 A	- 120.631	0.023 V	0.000 A	0.000
19	0.365 V	0.005 A	- 124.721	0.367 V	0.005 A	- 125.238	0.369 V	0.000 A	0.000
20	0.019 V	0.000 A	- 31.907	0.019 V	0.001 A	- 29.693	0.019 V	0.000 A	0.000
21	0.112 V	0.009 A	- 76.700	0.110 V	0.009 A	- 76.245	0.113 V	0.000 A	0.000
22	0.024 V	0.000 A	- 123.822	0.024 V	0.000 A	- 100.721	0.024 V	0.000 A	0.000
23	0.181 V	0.008 A	- 33.312	0.178 V	0.008 A	- 34.111	0.177 V	0.000 A	0.000
24	0.021 V	0.001 A	- 125.198	0.021 V	0.001 A	- 128.558	0.021 V	0.000 A	0.000
25	0.137 V	0.004 A	- 54.986	0.139 V	0.004 A	- 56.754	0.135 V	0.000 A	0.000
26	0.019 V	0.001 A	- 11.749	0.019 V	0.001 A	- 17.541	0.020 V	0.000 A	0.000
27	0.165 V	0.008 A	- 157.578	0.176 V	0.008 A	- 157.182	0.169 V	0.000 A	0.000
28	0.025 V	0.001 A	- 59.668	0.025 V	0.001 A	- 59.911	0.026 V	0.000 A	0.000
29	0.132 V	0.003 A	- 153.161	0.134 V	0.003 A	- 153.379	0.132 V	0.000 A	0.000
30	0.019 V	0.001 A	- 168.572	0.019 V	0.001 A	- 156.431	0.020 V	0.000 A	0.000
31	0.093 V	0.005 A	- 2.969	0.091 V	0.005 A	- 3.926	0.093 V	0.000 A	0.000
32	0.020 V	0.001 A	- 111.785	0.020 V	0.001 A	- 89.579	0.020 V	0.000 A	0.000
33	0.066 V	0.004 A	- 68.404	0.070 V	0.004 A	- 68.362	0.067 V	0.000 A	0.000
34	0.024 V	0.001 A	- 11.136	0.025 V	0.001 A	- 1.014	0.024 V	0.000 A	0.000
35	0.079 V	0.003 A	- 111.518	0.077 V	0.003 A	- 114.102	0.079 V	0.000 A	0.000
36	0.022 V	0.001 A	- 112.394	0.022 V	0.001 A	- 137.891	0.022 V	0.000 A	0.000
37	0.114 V	0.004 A	- 71.564	0.112 V	0.004 A	- 72.954	0.113 V	0.000 A	0.000
38	0.023 V	0.001 A	- 151.160	0.024 V	0.001 A	- 133.692	0.024 V	0.000 A	0.000
39	0.054 V	0.003 A	- 118.701	0.055 V	0.003 A	- 118.698	0.055 V	0.000 A	0.000
40	0.025 V	0.001 A	- 20.296	0.026 V	0.001 A	- 22.584	0.025 V	0.000 A	0.000

Left side of the acquisition data window

Of the elements displayed here:
Measured Data .bt1
Waveform data .bw1

Center of the acquisition data window

Of the elements displayed here:
Measured Data .bt2
Waveform data .bw2

Right side of the acquisition data window

Of the elements displayed here:
Measured Data .bt3
Waveform data .bw3

6.3 Saving Harmonic Measurement Data in CSV Format

Procedure

When the measurement mode is set to Harmonic Measurement and the measurement data has been retrieved (or loaded), the harmonic measurement data can be saved in CSV format.

Note

- Harmonic measurement data cannot be saved in CSV format when the measurement mode is set to Harmonic Monitor or Waveform Monitor or when no measured data is present.
- Harmonic measurement data cannot be saved in CSV format when measurement is in progress.

1. From the **File** menu, point to **Save**, then choose **Save Harmonic Data (CSV)**. The Save As dialog box opens. You can also select **Save Harmonic Data (CSV)** from the **Save** icon on the toolbar.

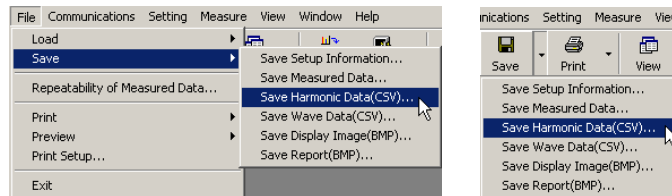

Selecting the Data to Be Saved

2. Select **Current** or **Voltage**.
3. Select the **Element** (input element).

The input element on which harmonic measurement is made varies depending on the wiring system configuration of the WT that you are using (see chapter 8). Therefore, input element to be saved also varies.
4. After selecting a folder in the **Save in** box, enter the name of the file you wish to save in the **File name** box.
5. Click **Save**. The harmonic measurement data is saved in CSV format.

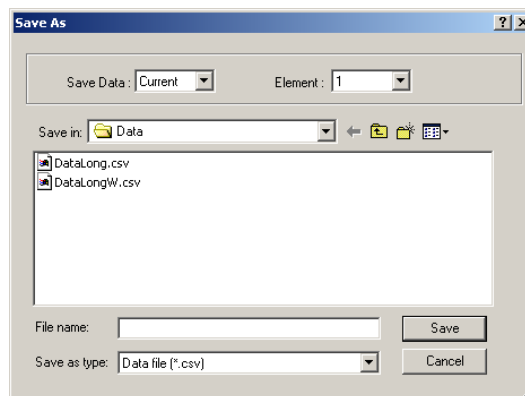

6.3 Saving Harmonic Measurement Data in CSV Format

Explanation

When the measurement mode is set to Harmonic Measurement and the measurement data has been retrieved (or loaded), the harmonic measurement data can be saved in CSV format. A file in CSV format can be opened using a spreadsheet application (such as Microsoft Excel) on your PC.

File Name, Extension, and Data Size

The file name can be any legal file name as defined by the PC that you are using.

- Extension: .csv
- Data size: Approx. 300 K (when the measurement time is 2 min. 30 s)

Example When the Harmonic Measurement Data Saved in CSV Format Is Opened Using Excel

Data being measured
Current in this example.

Date/Time the file was saved Input element being measured
Element 1 in this example.

	A	B	C	D	E	Order	H	I
1	DATE : Mon	Current	Element 1					
2		1	2	3	4	5	6	7
3	1	0.5108	0.006	0.3155	0.0051	0.1641	0.0052	0.0766
4	2	0.5108	0.0057	0.3155	0.005	0.1643	0.0052	0.0769
5	3	0.5108	0.0059	0.3155	0.0048	0.1643	0.0051	0.0768
6	4	0.5107	0.0059	0.3154	0.0052	0.1641	0.0053	0.0766
7	5	0.5106	0.0062	0.3153	0.0051	0.164	0.0053	0.0767
8	6	0.5105	0.0058	0.3153	0.005	0.1639	0.0052	0.0764
9	7	0.5107	0.0058	0.3153	0.0049	0.1639	0.0052	0.0764
10	8	0.5105	0.0059	0.3153	0.0048	0.164	0.0051	0.0766
11	9	0.5105	0.0057	0.3152	0.0047	0.1638	0.005	0.0763
12	10	0.5103	0.006				0.0051	0.0765
13	11	0.5103	0.0059				0.0052	0.0765
14	12	0.5101	0.0059	0.315	0.0048	0.164	0.005	0.0766
15	13	0.5102	0.0056	0.3151	0.0047	0.164	0.0051	0.0766
16	14	0.5103	0.0058	0.3151	0.0049	0.1638	0.0051	0.0763
17	15	0.5102	0.006	0.315	0.005	0.1638	0.0052	0.0764
18	16	0.5102	0.0058	0.315	0.0051	0.1638	0.0052	0.0764
19	17	0.5103	0.006	0.3151	0.0054	0.1637	0.0054	0.0763
20	18	0.5101	0.0063	0.315	0.0058	0.1637	0.0057	0.0764
21	19	0.5101	0.0061	0.315	0.0057	0.1636	0.0057	0.0763
22	20	0.5103	0.006	0.3151	0.0055	0.1635	0.0055	0.0761
23	21	0.5101	0.0061	0.3149	0.0052	0.1634	0.0053	0.076
24	22	0.51	0.006	0.3149	0.0055	0.1633	0.0055	0.0759
25	23	0.5102	0.0061	0.315	0.0055	0.1634	0.0055	0.0758
26	24	0.5101	0.0063	0.315	0.0056	0.1633	0.0056	0.0758
27	25	0.5102	0.006	0.3151	0.0056	0.1636	0.0056	0.0762
28	26	0.5103	0.0061	0.3151	0.0056	0.1635	0.0055	0.076
29	27	0.5101	0.0063	0.315	0.0057	0.1635	0.0056	0.0761

Harmonic measurement values

6.4 Saving Waveform Data in CSV Format

Procedure

When the measurement mode is set to Harmonic Measurement and the waveform data has been retrieved (or loaded), the waveform data can be saved in CSV format.

Note

- Waveform data cannot be saved in CSV format when the measurement mode is set to Harmonic Monitor or Waveform Monitor or when waveform data in Harmonic Measurement Mode is not present.
- Waveform data cannot be saved in CSV format when measurement is in progress.

1. From the **File** menu, point to **Save**, then choose **Save Wave Data (CSV)**. The Save As dialog box opens. You can also select **Save Wave Data** from the **Save** icon on the toolbar.

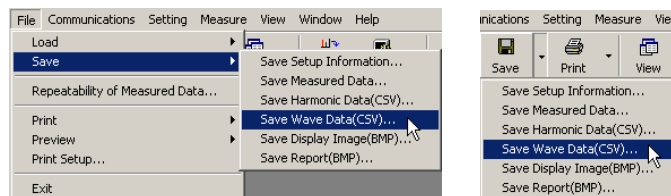

Selecting the Data to Be Saved

2. Select **Current** or **Voltage**.
3. Select the **Element** (input element).

The input element on which harmonic measurement is made varies depending on the wiring system configuration of the WT that you are using (see chapter 8). Therefore, input element to be saved also varies.
4. After selecting a folder in the **Save in** box, enter the name of the file you wish to save in the **File name** box.
5. Click **Save**. The waveform data is saved in CSV format.

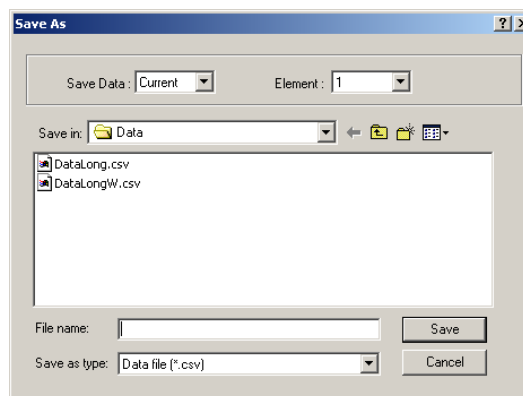

6.4 Saving Waveform Data in CSV Format

Explanation

When the measurement mode is set to Harmonic Measurement and the waveform data has been retrieved (or loaded), the waveform data can be saved in CSV format. A file in CSV format can be opened using a spreadsheet application (such as Microsoft Excel) on your PC.

- The data that is saved is the waveform data that is retrieved immediately after the measurement is finished with the measurement mode set to Harmonic Measurement.
- The waveform data (approximately 2 periods) is expressed using 2200 data points.

File Name, Extension, and Data Size

The file name can be any legal file name as defined by the PC that you are using.

- Extension: .csv
- Data size: Approx. 40 KB

Example When the Waveform Data Saved in CSV Format Is Opened Using Excel

Data being measured
Current in this example.

Date/Time the file was saved Input element being measured
Element 1 in this example.

	A	B	C	D	E	F	G	H
1	DATE : Mo	Current	Element 1					
2	1	0.1951						
3	2	0.17793						
4	3	0.16182						
5	4	0.14411						
6	5	0.12425						
7	6	0.10439						
8	7	0.08775						
9	8	0.07165						
10	9	0.05662						
11	10	0.04535						
12	11	0.0373						
13	12	0.03086						
14	13	0.02925						
15	14	0.02925						
16	15	0.03032						
17	16	0.033						
18	17	0.03461						
19	18	0.03461						
20	19	0.03461						
21	20	0.03515						
22	21	0.03461						
23	22	0.03461						
24	23	0.03837						
25	24	0.03944						
26	25	0.04105						
27	26	0.04159						
28	27	0.04105						
29	28	0.04159						

Waveform data values
Current in this example:

Number of waveform data points (up to 2200)

6.5 Checking the Repeatability of the Measured Data

Procedure

Note

You cannot check the repeatability of the waveform data while measurement is in progress.

Selecting the Files to Be Compared

1. From the **File** menu, choose **Repeatability of Measured Data**. The Repeatability of Measurement Data dialog box opens.

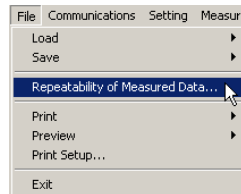

2. Click the file to be compared or enter the name of the file to be compared in the File name box.
3. Click **Open**. The file shown in the File name text box is displayed in the list of files to be compared.
4. Repeat steps 2 and 3 to select all the files to be compared.
5. Click **Exec**. Repeatability of Measurement Data window opens.
 - For multi-phase equipment, it is recommended that files of the same input element (same phase) be selected and the data be compared. The repeatability cannot be evaluated correctly when using measured data of different phases.
 - Even if only one file is selected, the Repeatability of Measurement Data window will open. In this case, no comparison is made.

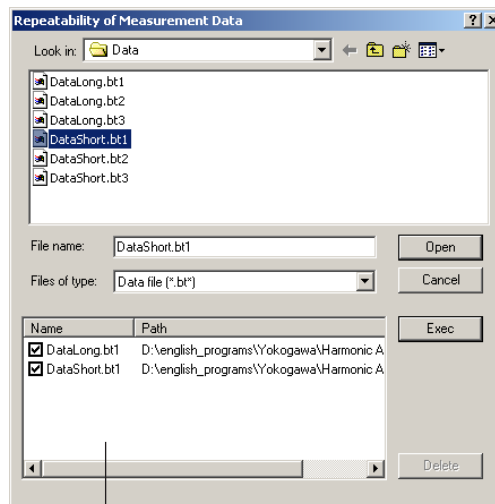

Files to be compared

6.5 Checking the Repeatability of the Measured Data

Evaluating the Repeatability

- Select **Average comparison** or **Maximum comparison**. The result of the comparison using the selected values is displayed on the bar graph and list.

Example of Average Comparison: The difference in all harmonics is within 5%.

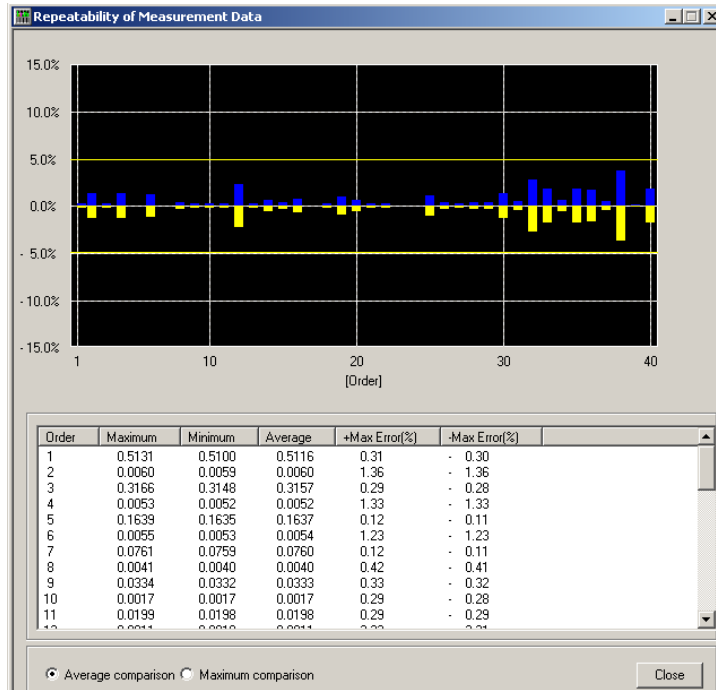

Example of Maximum Comparison: The difference at order 26 exceeds 5%.

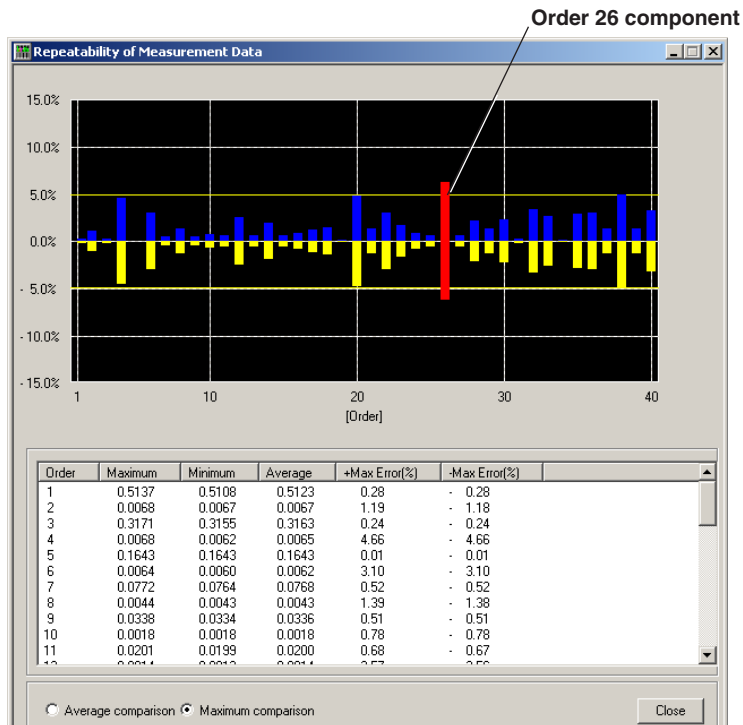

Explanation

The maximum value and mean value in the harmonics measurement data saved to files can be compared, and the difference in the measured data can be displayed on a bar graph and list for each order. This function can be used to evaluate whether the difference between data measured under the same measurement conditions when harmonics are measured using the same product or same product model is within 5% as defined in the standard (confirmation of repeatability).

Repeatability of Measurement Data Window

The following figure shows an example when maximum values are compared.

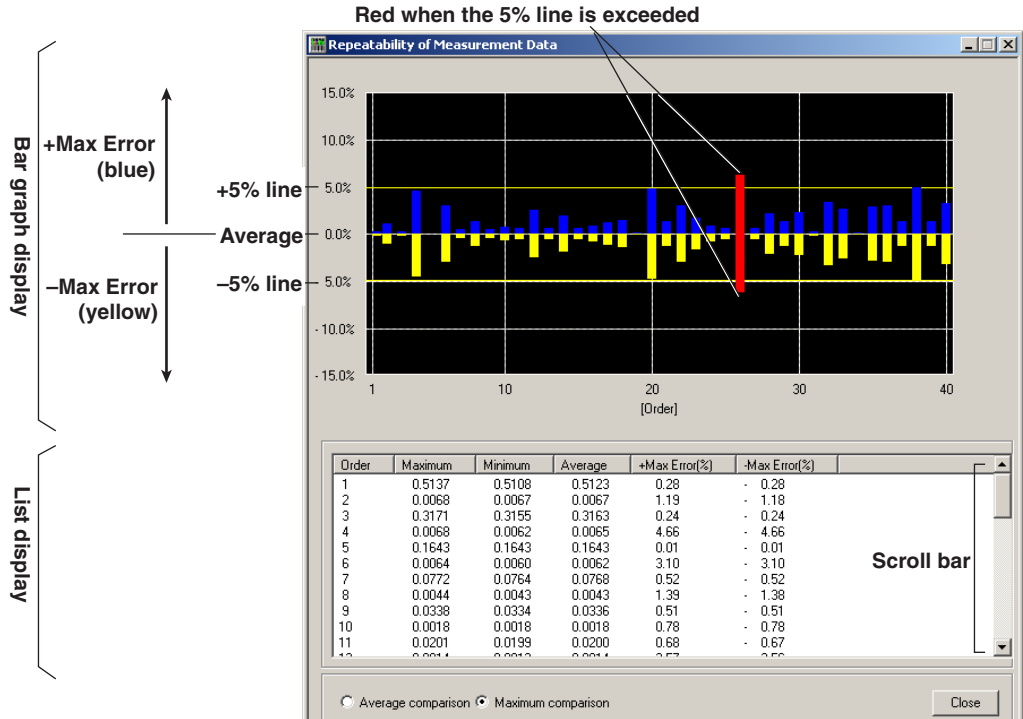

• **When Maximum Values Are Compared**

Maximum (Mxmax)

Maximum value among the maximum values of each order

Minimum (Mxmin)

Minimum value among the maximum values of each order

Average (Mxmean)

Average of the maximum values of each order of the selected file

+Max Error

Ratio (%) of the difference between Mxmax and Mxmean of each order

$$\frac{Mxmax - Mxmean}{Mxmean} \times 100$$

-Max Error

Ratio (%) of the difference between Mxmin and Mxmean of each order

$$\frac{Mxmin - Mxmean}{Mxmean} \times 100$$

6.5 Checking the Repeatability of the Measured Data

- **When Using Average Values Are Compared**

- **Maximum (Mnmax)**

- Maximum value among the average values of each order

- **Minimum (Mnmin)**

- Minimum value among the average values of each order

- **Average (Mnmean)**

- Average of the average values of each order of the selected file

- **+Max Error**

- Ratio (%) of the difference between Mnmax and Mnmean of each order

$$\frac{\text{Mnmax} - \text{Mnmean}}{\text{Mnmean}} \times 100$$

- **-Max Error**

- Ratio (%) of the difference between Mnmin and Mnmean of each order

$$\frac{\text{Mnmin} - \text{Mnmean}}{\text{Mnmean}} \times 100$$

Color

- **Bar Graph**

The bar graph that is displayed for each order is displayed using a length converted from the +Max Error or -Max Error. The meaning of the colors is indicated in the following table.

- **Blue**

- Difference (error) less than the +5% line for +Max Error.

- **Yellow**

- Difference (error) less than the -5% line for -Max Error.

- **Red**

- Difference (error) greater than the +5% line for +Max Error.

- Difference (error) greater than the -5% line for -Max Error.

* The names of the sample colors of Microsoft Word or Excel are used for the names of the colors.

- **List**

The maximum, minimum, average, +maximum error, and -maximum error for each order are displayed using values in black.

Number of Files That Can Be Compared

To evaluate the repeatability of the measured data, multiple files must be selected.
Number of files that can be compared: 2 to 10

Note

- For multi-phase equipment, it is recommended that files of the same input element (same phase) be selected and the data be compared. The repeatability cannot be evaluated correctly when using measured data of different phases.
 - Even if only one file is selected, the Repeatability of Measurement Data window will open. In this case, no comparison is made.
 - To evaluate the repeatability, check that the measured data saved to the file to be compared was measured under the following conditions.
 - Same DUT (not the same model, but the same equipment).
 - Same test conditions.
 - Same test equipment.
 - Same atmospheric conditions (when the DUT is affected by them).
-

7.1 Saving Screen Image Data in BMP Format

Procedure

1. From the **File** menu, point to **Save**, then choose **Save Display Image (BMP)**. The Save As dialog box opens. You can also select **Save Display Image** from the **Save** icon on the toolbar.

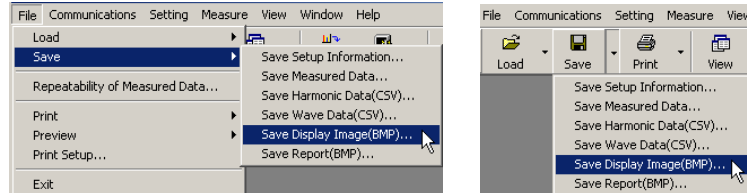

2. After selecting a folder in the **Save in** box, enter the name of the file you wish to save in the **File name** box.
3. Click **Save**. The screen image data that is present when Save is clicked is saved to a file in BMP format.

If you attempt to save the file using an existing file name, an overwrite warning message appears. In this case, the screen image data that is present when Yes is clicked is saved to a file in BMP format.

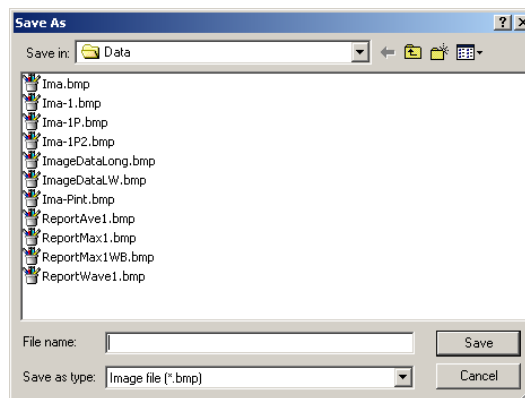

7.1 Saving Screen Image Data in BMP Format

Explanation

The screen image data of an active window such as acquisition data, bar graph, list, and waveform windows can be saved to a file in BMP format.

File Name, Extension, and Data Size

The file name can be any legal file name as defined by the PC that you are using.

- Extension: .bmp
- Data size: Approx. 2.5 MB maximum. The data size varies depending on the window being saved and the display setting of your PC.

Example When the Saved Screen Image Data Is Inserted in a Word Processor Application (Such as Microsoft Word)

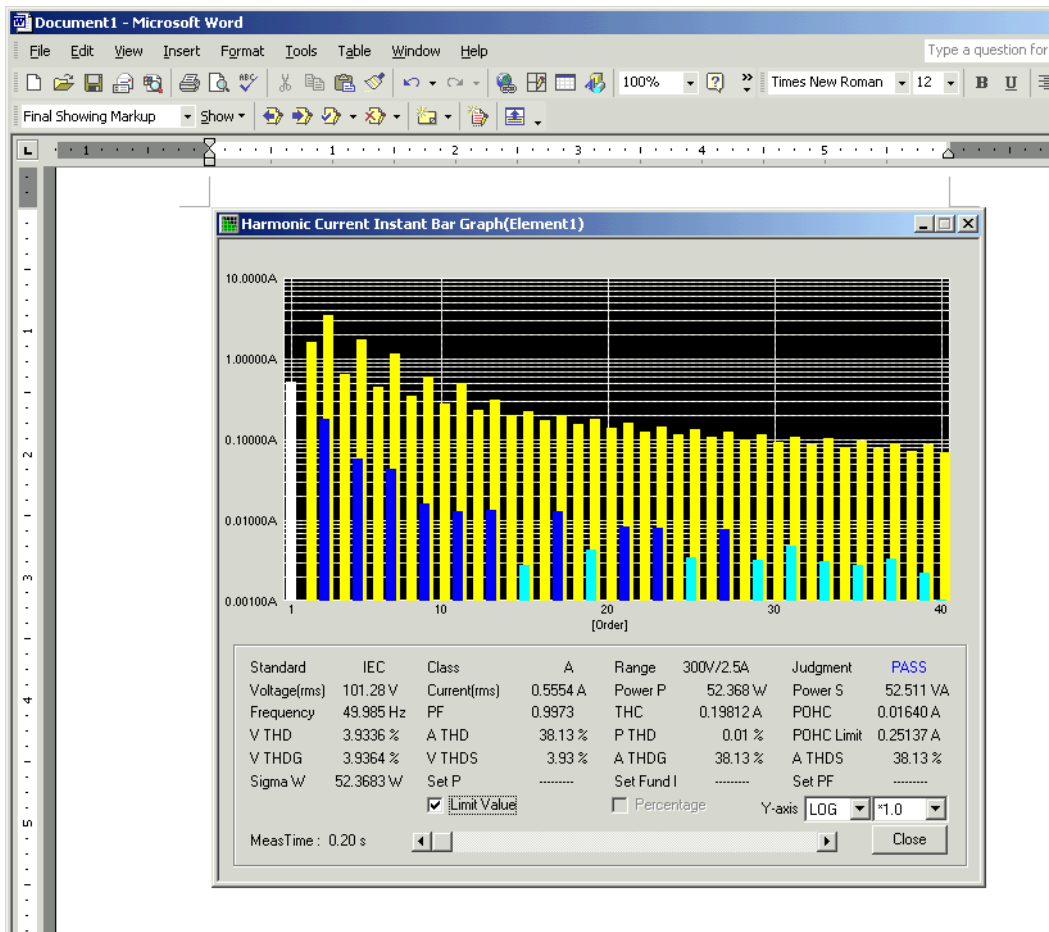

Note

You may not be able to open the BMP file saved using the software depending on the image processing software.

7.2 Setting Titles/Comments of Reports and Saving Reports in BMP Format

Procedure

Note

- Reports cannot be saved in BMP format when the measurement mode is set to Harmonic Monitor or Waveform Monitor or when no measured data or waveform data is present.
- You cannot set the title/comment of reports or save reports to BMP format while measurement is in progress.

Setting the Title/Comment of Reports

1. From the **Setting** menu, choose **Report Setup**. The Report Setup dialog box opens. You can also choose **Report Setup** from the **Setup** icon on the toolbar.



2. Enter appropriate text in the **Report Title** and **Report Comment** text boxes.
3. Select **Color** or **Mono** for the print mode.
4. Click **OK**.

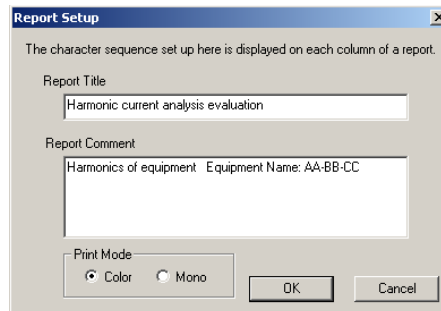

Saving Reports in BMP Format

When the measurement mode is set to Harmonic Measurement and the measurement data has been retrieved (or loaded), reports can be saved in BMP format.

1. From the **File** menu, point to **Save**, then choose **Save Report (BMP)**. The Save Report File dialog box opens. You can also select **Save Report** from the **Save** icon on the toolbar.

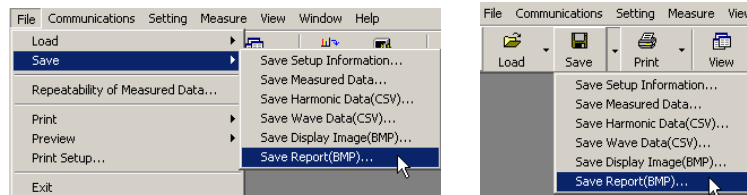

7.2 Setting Titles/Comments of Reports and Saving Reports in BMP Format

- **Selecting the Data for Creating the Report and Setting the Save Destination of the Report**
2. Select the **Element** (input element).

The input element on which harmonic measurement is made varies depending on the wiring system configuration of the WT that you are using (see chapter 8). Therefore, the selectable input element to be saved also varies.
 3. Select the **Average**, **Maximum**, or **Wave** check box to select the data for creating the report.
 - You can select multiple items.
 - The Wave check box becomes selectable only for Class C equipment with active input power less than or equal to 25 W, because the waveform data is used for evaluation only in this case.
 4. Check the save destination of the report selected in step 3. To change the save destination, click **File** on the same line. The Save As dialog box opens.

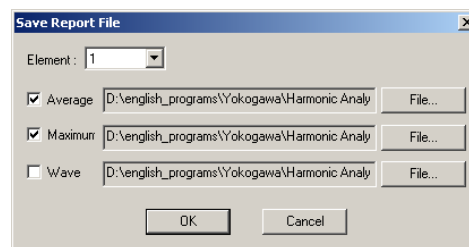

5. After selecting a folder in the **Save in** box, enter the name of the file you wish to save in the **File name** box.
6. Click **Save**. The screen returns to the Save Report File dialog box.
7. Repeat steps 4 to 6 to set the save destination of all reports to be created.

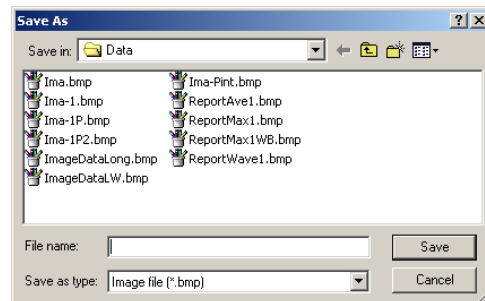

- **Executing the Save Operation**
8. Click **OK**.

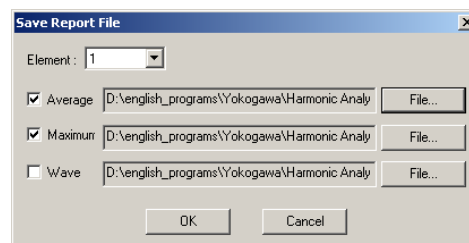

Explanation

Reports can be created and saved to BMP format using the data measured by the software.

Setting the Title/Comment of Reports

As necessary, you can enter a title and comment of the report that are saved along with the report when the report is saved to BMP format.

- **Number of Characters That Can Be Entered**

See the table below.

Item	Number of Characters That Can Be Entered
Title	Up to 50 characters.
Comment	Up to 50 characters.

- **Print Mode**

You can select whether to print the report in color or in black and white. To print the bar graph using different colors, it is recommended that the printing be done in color. For a description of the print preview and print procedure, see sections 7.4 and 7.5, respectively.

Saving the Report in BMP Format

When the measurement mode is set to Harmonic Measurement and the measurement data has been retrieved (or loaded), reports can be saved in BMP format.

- **Selecting the Data for Creating Reports**

Reports can be created for each input element. The print preview (see section 7.4) of the report can be displayed using the software. The saved report can also be inserted into a word processing (such as Microsoft Word) document to be displayed or printed (see sections 7.3 to 7.5).

- You can select average, maximum, and/or waveform data for creating the report.
 - You can select multiple items.
 - The Wave check box becomes selectable only for Class C equipment with active input power less than or equal to 25 W, because the waveform data is used for evaluation only in this case.
 - * Average: Average of the individual data points (instantaneous values) within the measurement time for each order.
 - Maximum: The maximum value among the individual data points (instantaneous values) within the measurement time for each order.
- The input element on which harmonic measurement is made varies depending on the wiring system configuration of the WT that you are using (see chapter 8). Therefore, the selectable input element to be saved also varies.

- **Saving the Report**

The title/comment (see above) entered in advance can be saved along with the report. When saving the average, maximum, and wave reports, assign a separate name for each report.

- **File Name, Extension, and Data Size**

The file name can be any legal file name as defined by the PC that you are using.

- Extension: .bmp
- Data size: Approx. 2.5 MB maximum. The data size varies depending on the window being saved and the display setting of your PC.

7.2 Setting Titles/Comments of Reports and Saving Reports in BMP Format

Example When the Saved Report (Average) Is Loaded to a Word Processor Application (Such as Microsoft Word)

For a description of the items displayed in the report, see section 1.6.

Harmonic current evaluation (Average)

Date :
 Comment : Prototype Pattern A

Regulation : IEC
 Class : CLASS A **PASS**
 MeasureTime : 150.18 Sec
 Model : YOKOGAWA WT3000
 Rating Voltage : 230.00 V
 Wiring : single-phase 2-wire
 Element : 1
 Range : 300V/2.5A
 Current(ms) : 0.5544 A
 Voltage(ms) : 101.48 V
 Frequency : 50.015 Hz
 Power Factor : 0.9973
 POHC Limit : 0.25137 A
 POHC Max : 0.01667 A
 THC : 0.19812 A

Fundamental Current :	
Set Power Factor :	
Set P :	
Sigma W Max : 52.3761 W	
Distortion factor(V) : 3.97 %	
VTHDS : 3.98 %	
VTHDG : 3.98 %	
Distortion factor(A) : 38.26 %	
ATHDS : 38.26 %	
ATHDG : 38.26 %	
P THD : 0.01 %	
Power Limit : 75 W	

Order	Measure[A]	Limit[A]	Margin[%]	Order	Measure[A]	Limit[A]	Margin[%]
1	0.5178			2	0.0005	1.08000	100.0
3	0.1810	2.30000	92.1	4	0.0005	0.43000	99.9
5	0.0588	1.14000	94.8	6	0.0005	0.30000	99.8
7	0.0441	0.77000	94.3	8	0.0005	0.23000	99.8
9	0.0185	0.40000	95.9	10	0.0004	0.18400	99.8
11	0.0131	0.33000	96.0	12	0.0004	0.15333	99.7
13	0.0133	0.21000	93.7	14	0.0005	0.13143	99.6
15	0.0029	0.15000	98.1	16	0.0004	0.11500	99.6
17	0.0131	0.13235	90.1	18	0.0005	0.10222	99.5
19	0.0044	0.11842	96.3	20	0.0005	0.09200	99.5
21	0.0083	0.10714	92.3	22	0.0005	0.08364	99.4
23	0.0080	0.09783	91.9	24	0.0007	0.07867	99.1
25	0.0035	0.09000	96.1	26	0.0006	0.07077	99.2
27	0.0078	0.08333	90.7	28	0.0008	0.06571	98.8
29	0.0030	0.07759	96.1	30	0.0007	0.06133	98.8
31	0.0048	0.07258	93.3	32	0.0007	0.05750	98.7
33	0.0030	0.06819	95.7	34	0.0009	0.05412	98.3
35	0.0029	0.06429	95.6	36	0.0008	0.05111	98.4
37	0.0034	0.06081	94.5	38	0.0010	0.04842	97.9
39	0.0023	0.05789	96.0	40	0.0011	0.04600	97.7

■ Limit ■ Over ■ N/A (1Hz) ■ Under (odd 2Hz)

Note

You may not be able to open the BMP file saved using the software depending on the image processing software.

7.3 Setting the Printer

Procedure

1. From the **File** menu, choose **Print Setup**. The Print Setup dialog box opens.

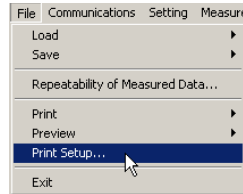

2. Enter appropriate settings for **Printer**, **Size**, **Source**, and **Orientation**.
3. Click **OK**.

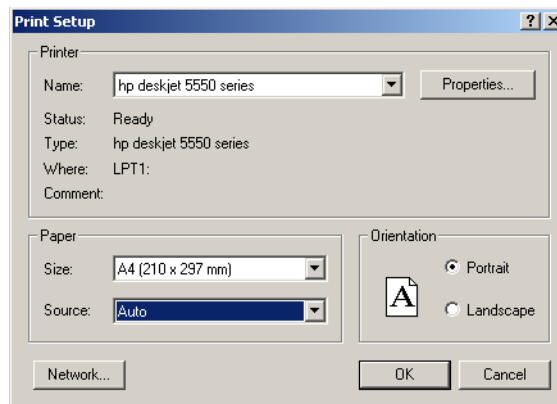

Note

Always use A4-sized paper when printing. Depending on the printer, some portions of the document may not be printed on the page if paper smaller than A4 is used.

Explanation

Set the printer according to the environment of the system that you are using.

7.4 Previewing the Printout

Procedure

Note

- Print preview of reports cannot be displayed when the measurement mode is set to Harmonic Monitor or Waveform Monitor or when no measured data or waveform data is present.
- Print preview of reports cannot be displayed when measurement is in progress.

Displaying the Print Preview of the Screen Image

1. From the **File** menu, point to **Preview** and then choose **Display Image**. The screen image that is present when Display Image is selected is previewed.

The screen image data of an active window such as acquisition data, bar graph, list, and waveform windows is previewed.

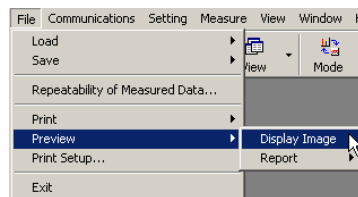

2. You can perform various operations such as **Next Page/Prev Page**, **One Page/Two Page**, and **Zoom In/Zoom Out**. Click **Print** to print the image (see section 7.5).

Display Example: Print Preview Window

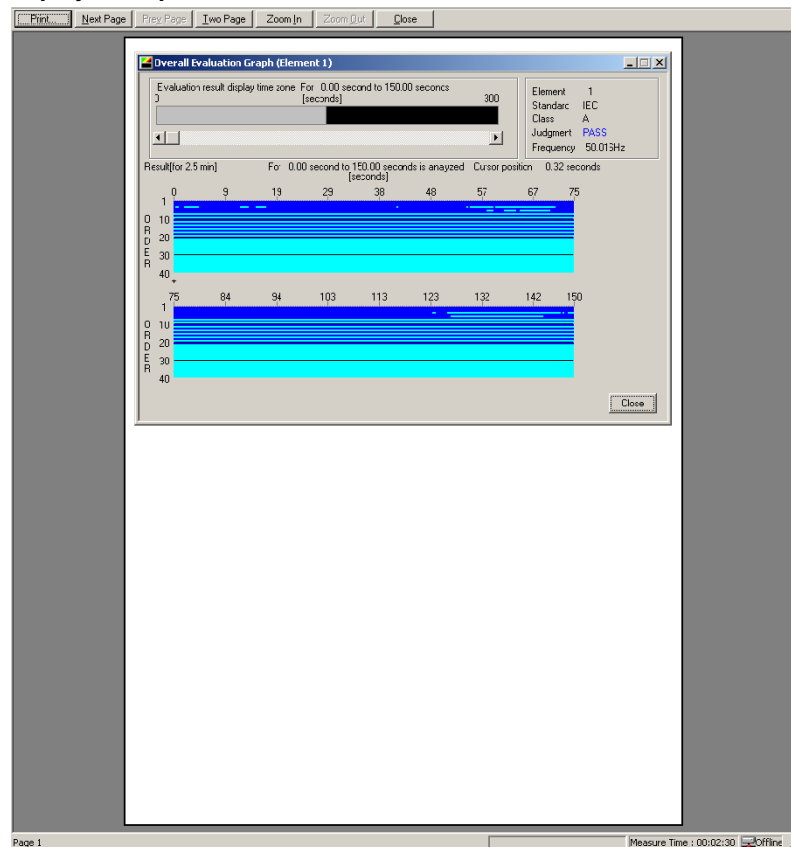

Displaying the Print Preview of Reports

The input element on which harmonic measurement is made varies depending on the wiring system configuration of the WT that you are using (see chapter 8). Therefore, the selectable input element to be previewed also varies. Below a procedure is given in which the wiring system of the WT3000 is set to single-phase two-wire (1P2W) and one input element is used.

When the measurement mode is set to Harmonic Measurement and the measured data or waveform data has been retrieved (or loaded), the print preview of the report can be displayed.

1. Choose **File > Preview > Report > Element1**. The report is previewed on the Report Preview window.

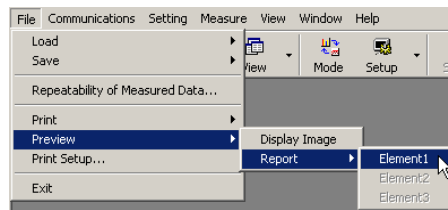

2. You can perform various operations such as **Next Page/Prev Page, One Page/Two Page**, and **Zoom In/Zoom Out**. Click **Print** to print the image (see section 7.5).

Display Example: Print Preview Window

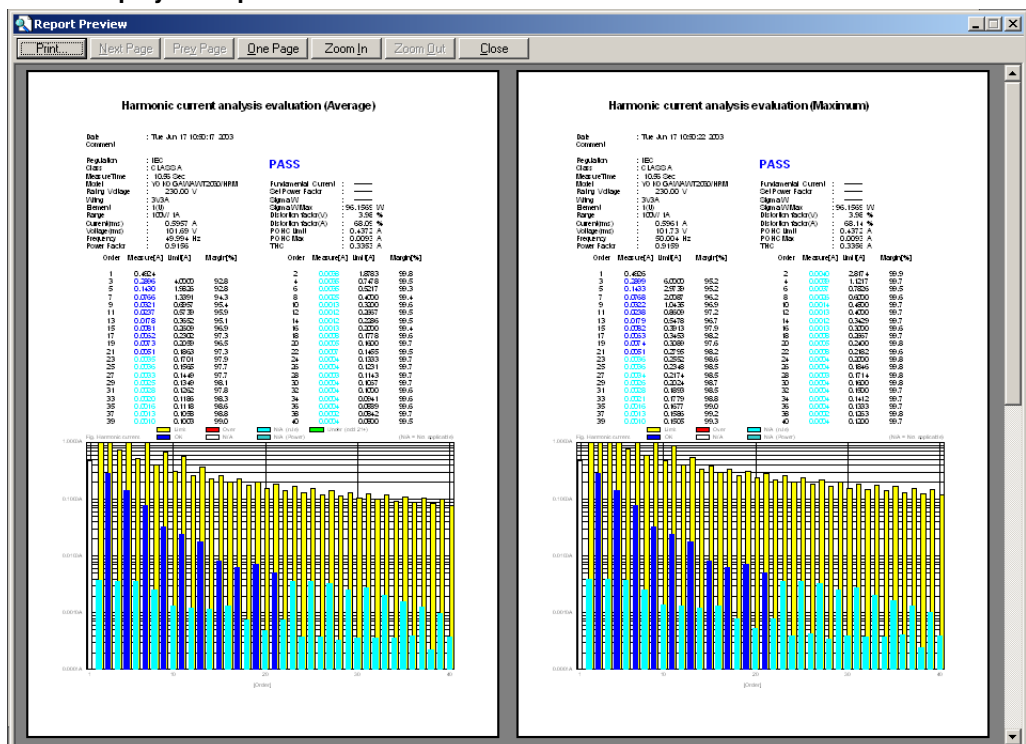

Explanation

You can preview the print image on the screen. Perform various operations on the print preview window according to the PC environment that you are using.

Print Preview of the Screen Image

The screen image data of an active window such as acquisition data, bar graph, list, and waveform windows is previewed.

Print Preview of Reports

When the measurement mode is set to Harmonic Measurement and the measured data or waveform data has been retrieved (or loaded), the report can be previewed.

- The report that uses the average and maximum data can be previewed for each input element.
 - * Average: Average of the individual data points (instantaneous values) within the measurement time for each order.
 - Maximum: The maximum value among the individual data points (instantaneous values) within the measurement time for each order.
- For Class C equipment, the limit that was used is also displayed.
- For Class C equipment with an active input power less than or equal to 25 W, waveforms as described in section 4.5 are also previewed, if waveforms are being used for evaluation.
- The input element on which harmonic measurement is made varies depending on the wiring system configuration of the WT that you are using (see chapter 8). Therefore, the selectable input element to be previewed also varies.

Selecting Color/Mono for Reports

The print mode is selected in the title/comment setting of reports (see section 7.2). If Color is selected there, the preview is displayed in color. If Mono is selected, the preview is displayed in black and white.

7.5 Printing

Procedure

Note

- Printing of reports cannot be displayed when the measurement mode is set to Harmonic Monitor or Waveform Monitor or when no measured data or waveform data is present.
- Reports cannot be printed when measurement is in progress.

Printing Screen Images

1. From the **File** menu, point to **Print** and then choose **Display Image**. The Print dialog box opens. You can also choose **Display Image** from the **Print** icon on the toolbar.

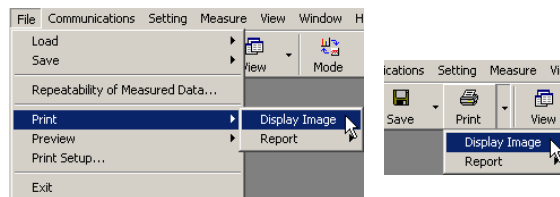

2. Set the **Printer**, **Print range**, and **Copies**.
3. Click **OK**. The screen image that was present when Display Image was selected in step 1 is printed.

The screen image data of an active window such as acquisition data, bar graph, list, and waveform windows is printed.

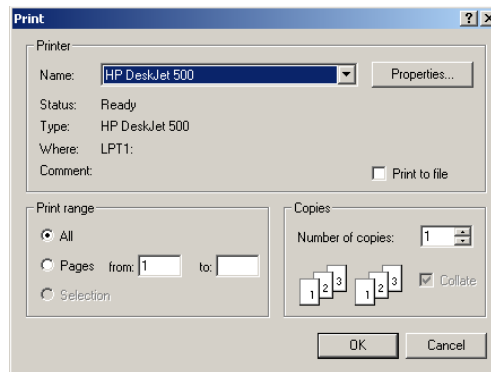

Print Example

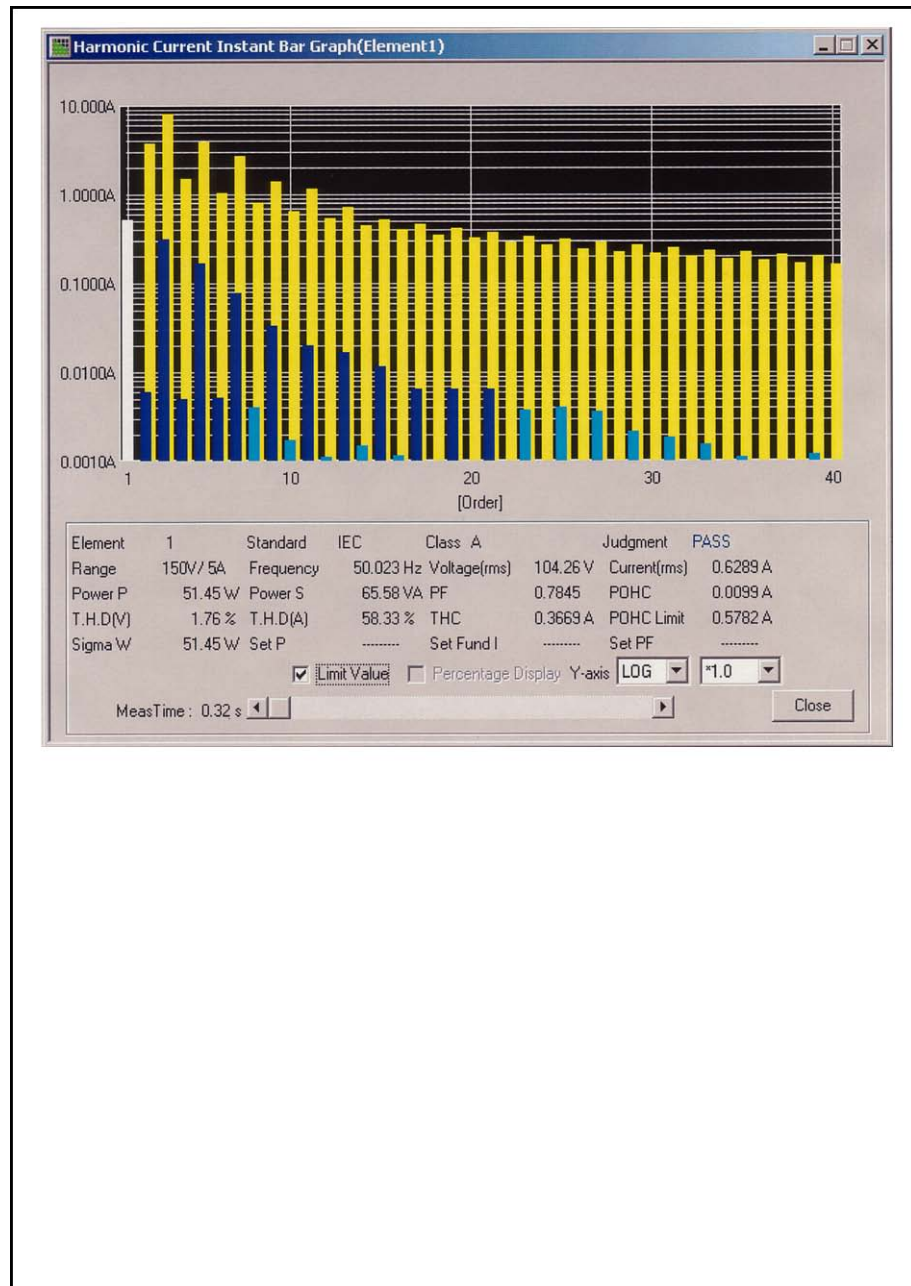

Printing Reports

The input element on which harmonic measurement is made varies depending on the wiring system configuration of the WT that you are using (see chapter 8). Therefore, the selectable input element to be printed also varies. Below a procedure is given in which the wiring system of the WT3000 is set to single-phase two-wire (1P2W) and one input element is used.

When the measurement mode is set to Harmonic Measurement Mode and the measurement data has been acquired (or loaded), the report can be printed.

1. Choose **File > Print > Report > Element1**. The Print dialog box opens. You can also choose **Print > Report > Element1** from the toolbar.

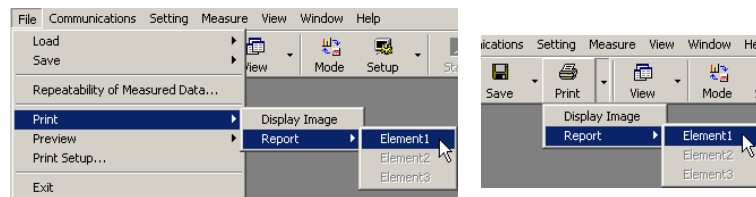

2. Set the **Printer, Print range, and Copies**.
3. Click **OK**. The reports that use the average and maximum data are printed on separate pages.

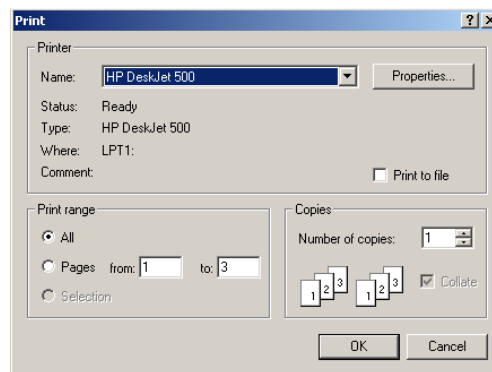

Print Example (Image)

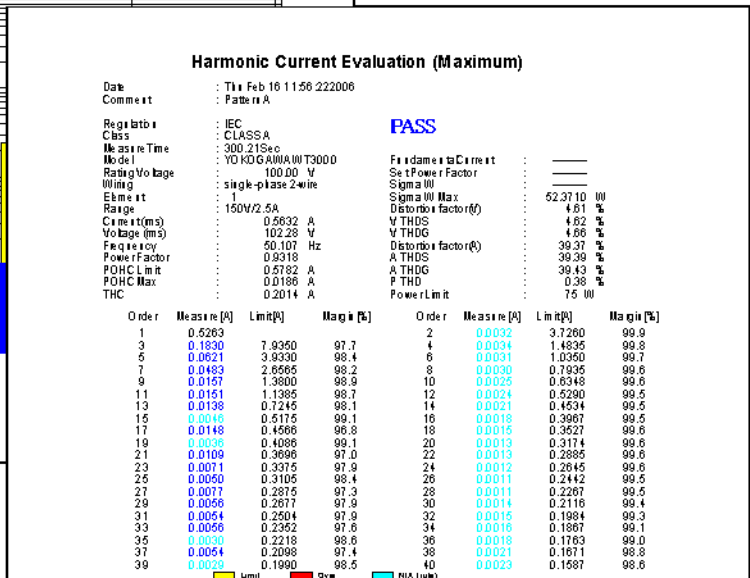
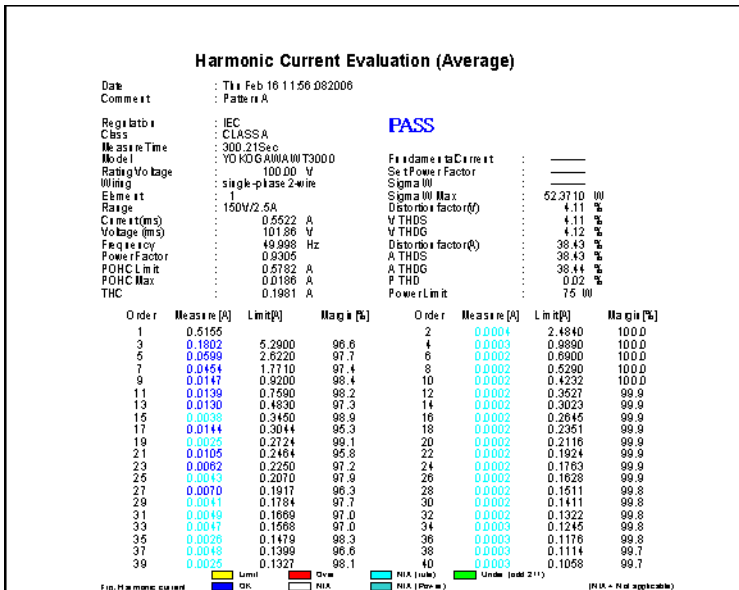

Explanation

Set the printer according to the environment of the system that you are using.

Printing Screen Images

The screen image data of an active window such as acquisition data, bar graph, list, and waveform windows is printed.

Printing Reports

When the measurement mode is set to Harmonic Measurement and the measured data has been retrieved (or loaded), the report can be printed.

- The report that uses the average and maximum data can be printed for each input element.

* Average: Average of the individual data points (instantaneous values) within the measurement time for each order.

Maximum: The maximum value among the individual data points (instantaneous values) within the measurement time for each order.

- For Class C equipment, the limit that was used is also printed.
- For Class C equipment with an active input power less than or equal to 25 W, waveforms as described in section 4.5 are also printed, if waveforms are being used for evaluation.
- The input element on which harmonic measurement is made varies depending on the wiring system configuration of the WT that you are using (see chapter 8). Therefore, the selectable input element to be printed also varies.

Selecting Color/Mono for Reports

The print mode is selected in the title/comment setting of reports (see section 7.2). If Color is selected there, the report is printed in color. If Mono is selected, the report is printed in black and white.

- **Printing of the Power Values That Are Excluded from Applying the Limits**

The power values that are excluded from applying the limits are printed for Classes A, B, and D. The printed contents vary depending on the selection made in “Selecting the Lower Power Limit for Applying the Limits” in section 3.5.

Lower Power Limit for Applying the Limits Selected in Section 3.5	Printed Contents
50W	50W
75W	75W
None	-----
Infinity	Always excluded from applying the limits

8.1 Setting the Measurement Conditions of the WT3000

Procedure

1. Select WT3000 in the Select WT dialog box. While online, choose **Setting > WT Setting**. You can also choose **WT Setting** from the **Setup** icon on the toolbar. You can set the measurement conditions of the target WT.

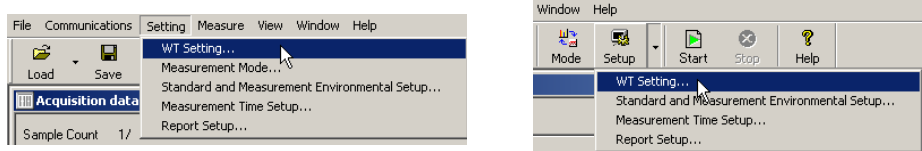

2. On the WT Setting dialog box, select the Simple Mode or Detail Mode tab.
3. Set the measurement conditions of the WT on the WT Setting dialog box. When an item is changed on the dialog box, the corresponding measurement condition of the target WT is changed.

Simple Mode Dialog Box

WT setup mode

Select the WT setup mode.

Wiring system

Select the wiring system of the measurement circuit.

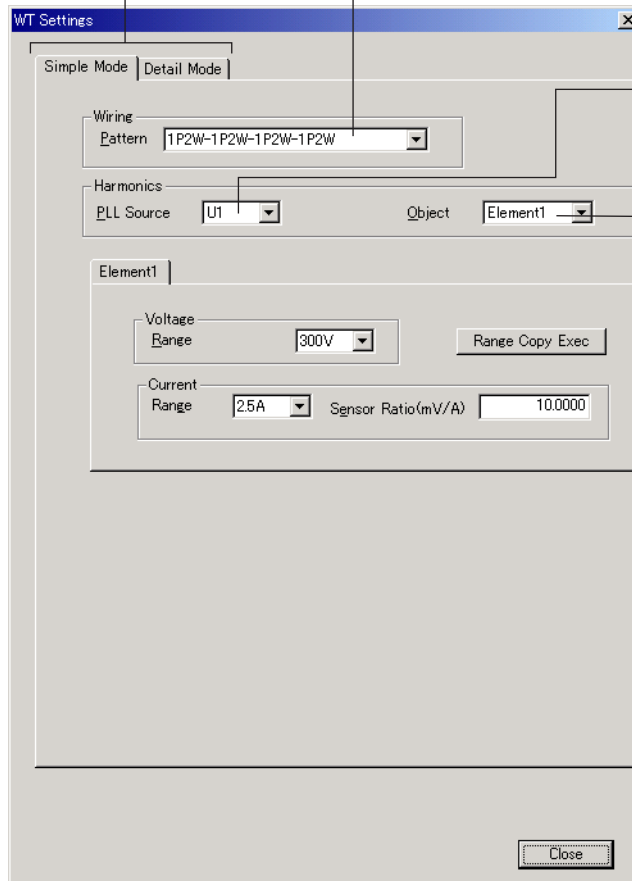

PLL source

Select the signal source of the fundamental period used as a reference for determining the harmonic orders.

Measured item

Select the wiring unit for measuring the harmonics.

Measurement range of voltage/current

Set for each element.

- Select the voltage range and current range.
- Set the scaling value of the external current sensor input.

8.1 Setting the Measurement Conditions of the WT3000

Detail Mode Dialog Box

WT setup mode
Select Simple Mode or Detail Mode.

Wiring system
Select the wiring system of the measurement circuit.

PLL source
Select the signal source of the fundamental period used as a reference for determining the harmonic orders.

Measured item
Select the wiring unit for measuring the harmonics.

Compensation for the two-wattmeter method
Select On or Off.

Measurement range of voltage/current
Set for each element.

- Select the wiring compensation.
- Turn the frequency filter On/Off.
- Select the voltage range and current range.
- Set the VT ratio, CT ratio, and scaling factor.
- Set the scaling value of the external shunt.
- Copy the filter to the same wiring units.
- Copy the range to the same wiring units.
- Copy the scaling to the same wiring units.

Note

- When the wiring system is pattern 1 (when all are 1P2W), filter, range, and scaling are copied to all other elements.
- When taking measurements with this software, the antialiasing filter cutoff frequency is fixed at 5.5 kHz.
- To make accurate measurements, turn ON the frequency filter of the input element set to PLL source.
- The exponential average function of the WT3000 is ON.

Explanation

The measurement conditions of the WT3000 can be set from the software via the GP-IB or Ethernet interface.

- For a description of the setting of the conditions used when retrieving the measured harmonic data into the PC, see chapter 3. For a description of the procedure of displaying the retrieved measurement data and waveform data, see chapters 4 and 5, respectively.
- The menu used to select the input element of the target data varies depending on the wiring system specified here when displaying or saving measured data/waveform data or creating, saving, or printing (see chapter 7) reports.
- When an item is changed on the dialog box, the corresponding measurement condition of the target WT is changed.
- The software starts communications with the target instrument when the software is started, the communication mode is set to On-Line mode, and the GP-IB address is selected. At this point, the software loads the measurement conditions of the target WT and applies the conditions to the settings shown on the WT Setting dialog box. If communication fails and the measurement conditions of the WT cannot be retrieved, the settings shown on the WT Setting dialog box become factory default settings of the WT.

For the setting details and setup procedure on the WT of the following parameters, see the referenced sections in the User's Manual IM760301-01E or IM760301-51E.

Parameter	Reference Section in the User's Manual	
Wiring system	IM760301-01E	Section 4.1
PLL source	IM760301-51E	Section 7.5
Compensation for the two-wattmeter method	IM760301-01E	Section 5.8
Wiring compensation	IM760301-01E	Section 5.8
Frequency filter	IM760301-01E	Section 4.8
Measurement range of voltage/current	IM760301-01E	Sections 4.3 and 4.4
Scaling	IM760301-01E	Section 4.5

9.1 Cascading/Tiling Graph and List Windows

Procedure

Cascading and tiling window functions are convenient for arranging the display.

Cascading Windows

From the **Window** menu, choose **Cascade**. Windows are cascaded so that the titles of all displayed windows can be seen.

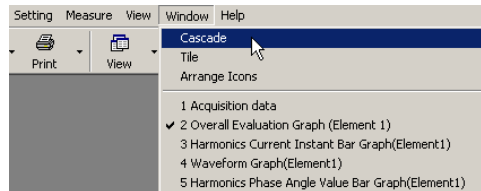

Display Example

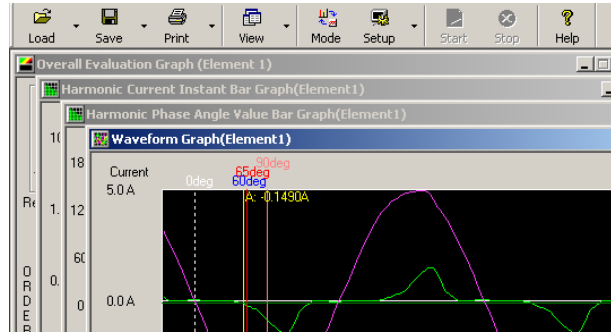

Tiling Windows

From the **Window** menu, choose **Tile**. All the displayed windows are tiled so that the windows do not overlap each other.

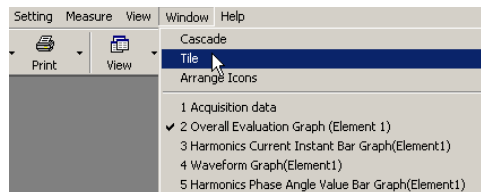

9.1 Cascading/Tiling Graph and List Windows

Display Example

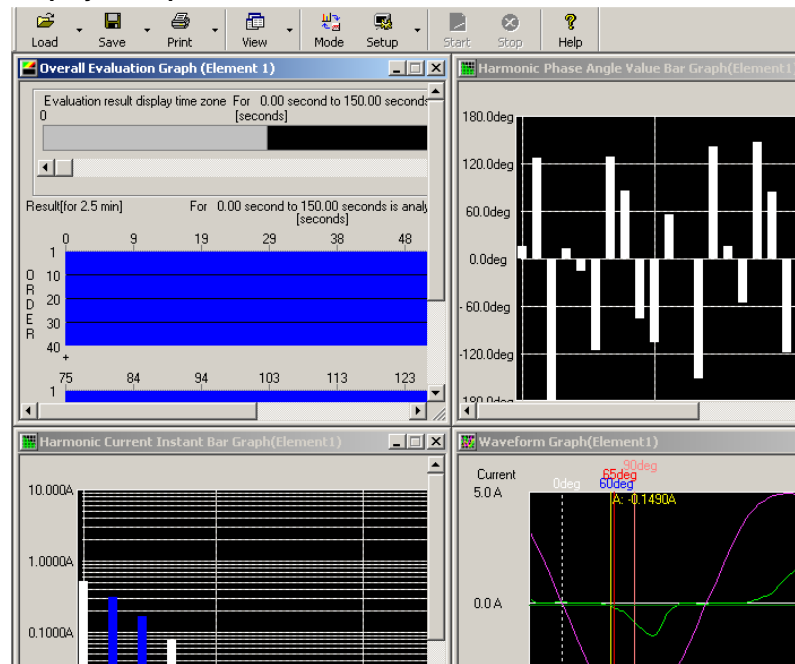

Explanation

Window functions are useful, when the measurement mode is set to Harmonic Measurement, the measured data is retrieved (or loaded), and multiple graphs or lists are displayed.

Cascade

- Windows are cascaded so that the title of all displayed windows can be seen.
- The active graph or list window becomes the front window after the cascade operation.
- The cascade order varies depending on the type of displayed window.

Tile

- All the displayed windows are tiled so that the windows do not overlap each other.
- The active graph or list window becomes the active window after the tile operation.
- The arrangement order varies depending on the type of displayed window.

9.2 Arranging Icons

Procedure

From the **Window** menu, choose **Arrange Icons**. All the minimized windows (icons) are arranged at the lower left corner of the main window of the software.

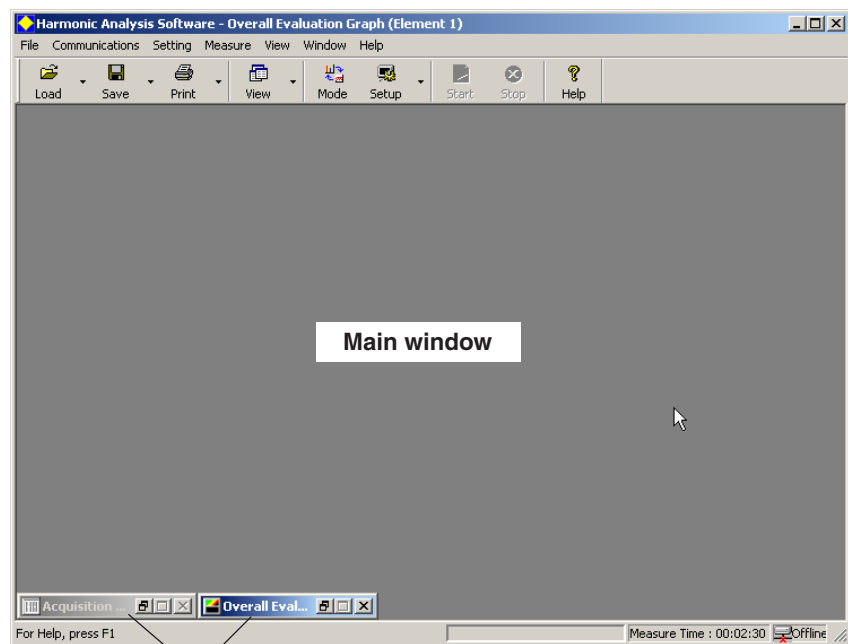
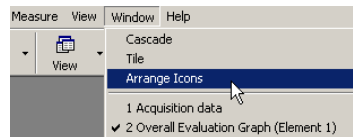

Explanation

This function is useful when various windows such as acquisition data, bar graph, and list windows have been minimized (icons) and the icons have been moved (within or outside the main window of the software).

9.3 Using the Help Function

Procedure

From the Help menu, point to Help Topics and choose User's Manual. If Adobe Reader is installed in the PC, Adobe Reader starts and shows the PDF file of the User's Manual of this software. You can also click  on the toolbar.

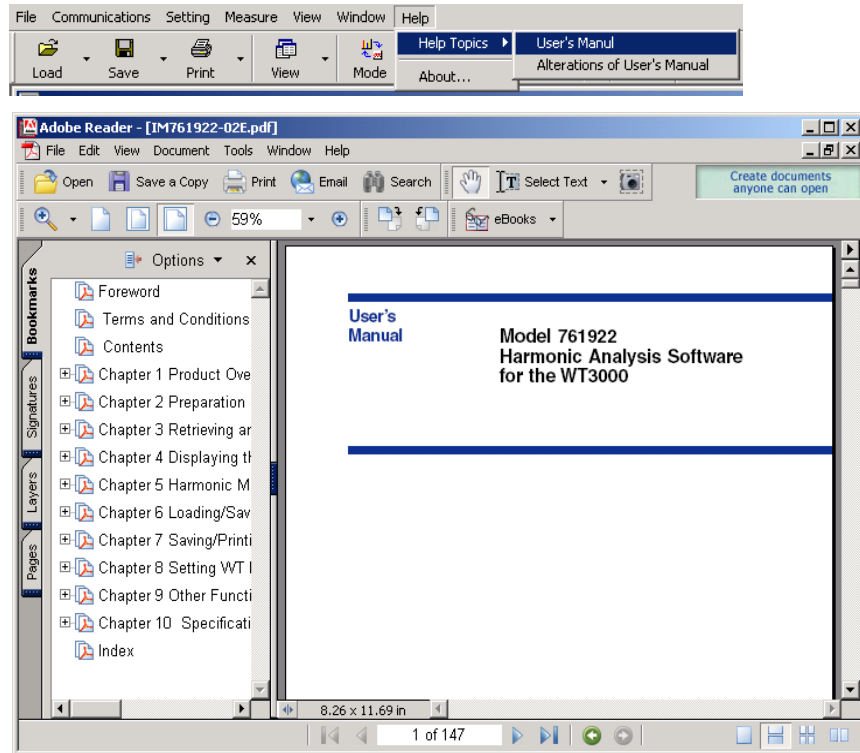

Explanation

Online Help

The user's manual is displayed as a help document in PDF (Portable Document Format). You can find information about operating procedures of this software and terminology.

You can view PDF files using Adobe Reader, a freeware.

If there is an alteration notice, you can choose **Help > Help Topics > Alteration Notice** from the toolbar to view the PDF file of the alteration notice.

Viewing the Most Recent User's Manual or Alteration Notice

To obtain the most recent PDF files of the user's manual and alteration notice, click "Manual Download" on the YOKOGAWA's Web page shown below. Then, download the users manual and alteration notice of this software program.

www.yokogawa.com/tm/wtpz/761922/tm-761922_01.htm

Rename the downloaded user's manual and alteration notice as indicated below according to the product that you are using, and copy (overwrite) the files in the software installation folder that you specified when you carried out the steps on page 2-8. You will be able to view the most recent operating instructions by selecting the user's manual or alteration notice from the Help menu.

Product	User's Manual File Name	Alteration Notice File Name
WT3000	IM761922-02E.pdf	AlterationsEWT3000.pdf
WT1600 WT2000 series	IM761922-01E.pdf	AlterationsEWT2000.pdf

Note

- You can download Adobe Reader from Adobe System's Web page.
 - The most recent user's manual and alteration notice that you can download from YOKOGAWA's Web page correspond to the most recent version of this software program. Update the software program as necessary. The program for updating the software can be downloaded from YOKOGAWA's Web page above.
-

9.4 Viewing Version Information

Procedure

From the **Help** menu, choose **About**. The Harmonic Analysis Software version information dialog box opens.



Harmonic Analysis Software Version Dialog Box

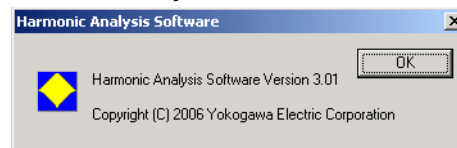

Explanation

The name and version information of the software is displayed.

Specifications

Item	Specifications
Software*	This software application (761922) measures harmonic currents of electrical equipment according to the IEC or JIS standard and indicates/saves the results of evaluations made according to the standard. The executable file name is IEC61000_3_2.exe.
Applicable instruments*	<ul style="list-style-type: none"> • WT3000 (models 760301, 760302, 760303, and 760304) • WT1600 (model 760101) • WT2000 series (models 253101, 253102, and 253103)
Applicable standard*	<p>IEC 61000-3-2 (Electromagnetic compatibility (EMC) - Part 3-2: Limits - Limits for harmonic current emissions (equipment input current \leq 16 A per phase)) Edition 2.2</p> <ul style="list-style-type: none"> • EN61000-3-2 (2000) • IEC61000-4-7 Edition 2 • JIS C61000-3-2 (2005), abbreviated as JIS
Functions	<p>Retrieving and loading measured data/waveform data to be evaluated</p> <ul style="list-style-type: none"> • Setting of WT measurement conditions. • Retrieving of measured data or waveform data from the WT connected online (On-Line Mode). • Loading of measured data or waveform data already saved (Off-Line mode). <p>Measurement mode*</p> <ul style="list-style-type: none"> • Harmonic Measurement Mode <ul style="list-style-type: none"> • When in On-Line Mode Measures and evaluates harmonics on the measurement data retrieved from the WT according to the method complying with IEC61000-3-2 Edition 2.2 or JIS. • When in Off-Line Mode Evaluation can be made on the loaded measurement data according to the method complying with IEC 61000-3-2 Edition 2.2 or JIS. • Harmonic Monitor Mode Monitor harmonic fluctuation on bar graphs and numerical list while making measurements on the WT only in On-Line mode. • Waveform Monitor Mode Monitor waveforms while making measurements on the WT on in On-Line mode. <p>Standard and measurement environment</p> <p>Sets the classification of the equipment under test (EUT) as defined in IEC 61000-3-2 Edition 2.2 or JIS and evaluation conditions within each class.</p> <p>Measurement time</p> <p>Time from measurement start to measurement stop. Selectable range: 0 H 0 M 1 S to 24 H 0 M 0 S in units of 1 s.</p> <p>Title/Comment of reports</p> <p>Sets the title/comment of reports. You can select color or black and white as well as Japanese or English for reports. Saved/Printed along with the measured data.</p> <p>Starting/Stopping of measurements</p> <p>Measurement can be started in On-Line mode.</p> <p>Displaying of the evaluation results and measured data/waveform data</p> <p>Only when the measurement mode is set to Harmonic Measurement, displays the result of the evaluation as whether the harmonic current data up is within the limits of IEC 61000-3-2 Edition 2.2 or JIS and the corresponding measured data.</p> <ul style="list-style-type: none"> • Display of the evaluation result within the entire measurement time Evaluates as to whether all of the harmonic measurement data in the measurement time are within the limits and display the results. • Bar graph display of harmonic current/voltage Displays bar graph of the harmonic measurement data and the standard limits for each order. • List display of harmonic current/voltage Displays a list of the harmonic measurement data and the standard limits for each order. • Fluctuation graph display of harmonic current Displays the graph of the harmonic current fluctuation over time for each order. • Waveform display of voltage/current Displays the waveform immediately after stopping measurement (approximately 2 periods of the waveform on the WT2000/WT3000 or approximately 4 periods on the WT1600). Place the cursor on the current waveform and read the phase difference (phase angle) from the first zero-crossing point of the voltage waveform and the current value.

Specifications

Item	Specifications
	<ul style="list-style-type: none"> • Fluctuation graph display of voltage/current/active power Displays the graph of the fluctuation of the rms value of the voltage and current as well as the active power that are determined from the measured fundamental signal and all harmonics. • Bar graph display of the phase angle of the harmonic current Displays the bar graph of the phase angle of the harmonic current with respect to the fundamental signal for each order. • List display of the phase angle of the harmonic current Displays a numerical list of the phase angle of the harmonic current with respect to the fundamental signal for each order. <p>Loading of setup information, measured data, and waveform data</p> <ul style="list-style-type: none"> • Saving and loading of data Save to a file setup data including the measurement mode, standard and measurement environment settings, measurement time, title/comment of reports. Loading of the setup data is also possible. • Loading of measured data and waveform data Save measured data or waveform data of harmonics to files. Setup data such as the measurement mode, standard and measurement environment settings, measurement time, title/comment of reports and the harmonic measurement conditions of the WT specified by the software are also saved. Loading of the saved measured data, waveform data, harmonic measurement conditions, and setup information is also possible. • Saving of the measured data or waveform data in CSV format Save the measured data or waveform data of harmonics to a file in CSV format. The saved data can be loaded on a PC software application supporting CSV format. <hr/> <p>Saving/Printing of screen images and reports Save screen images or reports to a file in BMP format. Printing also possible.</p> <hr/> <p>Repeatability of measured data Compares the harmonic measurement data that is saved to files, and displays the difference in the measured data on a bar graph and numerical list. Enables confirmation of whether the difference between data measured using the same product is within 5% as defined by the standard (confirmation of repeatability).</p>
System requirements	<p>PC</p> <ul style="list-style-type: none"> • CPU Pentium III 1 GHz or equivalent or faster • Memory 256 MB or more • Hard disk Free space of at least 2 GB. <hr/> <p>Operating System Windows 98, Windows Me, Windows 2000 Professional, Windows XP Home Edition, or Windows XP Professional.</p> <hr/> <p>Communication card</p> <ul style="list-style-type: none"> • GP-IB PCI-GPIB/PCI-GPIB+/PCMCIA GPIB/PCMCIA-GPIB+ by National Instruments with NI-488.2M driver version 1.60 or later. • Ethernet A 10BASE-T or 100BASE-TX Ethernet port. <hr/> <p>CRT, Printer, and Mouse Those compatible with Windows 98, Windows Me, Windows 2000 Professional, Windows XP Home Edition, or Windows XP Professional.</p> <hr/> <p>WT Digital Power Meter WT3000 firmware version 3.01 or higher with the following functions.</p> <ul style="list-style-type: none"> • Advanced computation function (option) • GP-IB interface (standard) or Ethernet interface (option)
*	<ul style="list-style-type: none"> • The width of the window function (measurement period) for the measurements on the WT3000 is 200 ms (10 cycles at 50 Hz and 12 cycles at 60 Hz) as defined by IEC61000-4-7 Edition 2. • The width of the window function (measurement period) for the measurements on the WT2000/WT1600 is 16 cycles as defined by IEC61000-4-7 (1991). • The WT1600 supports analysis methods based on the standard. However, measurements complying with the standard cannot be performed due to the limitation in the measurement accuracy.

Compatibility between the WT3000 Precision Power Analyzer and IEC

In the EN61000-3-2:2000 (IEC61000-3-2 Edition 2.2:2004) standard, the requirements for measurement instruments are specified in EN61000-4-7 (IEC61000-4-7).

The WT3000 complies with the items related to EN61000-3-2:2000 (IEC61000-3-2 Edition 2.2:2004) of EN61000-4-7:2002 (IEC61000-4-7 Edition 2:2002) in the range indicated in the table below.

Item	EN61000-4-7:2002 IEC61000-4-7 Edition 2:2002	WT3000	Compliance
Current measurement error	5% of the permissible limits or 0.15% I _r of the rated current I _r , whichever is greater	Frequency of the 40 th order of the fundamental frequency 60 Hz When the crest factor is 3, 2.5% of reading+0.05% of range → Error within 5% at the limit that is greater than or equal to 2% of the input range When the crest factor is 6, 2.5% of reading+0.1% of range → Error within 5% at the limit that is greater than or equal to 4% of the input range Accuracy at 2.4 kHz (direct input)	Compliant within the range in the left column for direct input
Instrumental loss of the current input circuit	Voltage drop of 0.15 V _{rms} or less	Instrumental loss Approx. 5.5 mΩ + approx. 0.03 μH	Complies up to approx. 27 Arms
Crest factor of the current input circuit	5 Arms range or less: 4 10 Arms range or less: 3.5 Range above 10 Arms: 2.5 Overload display is necessary.	3 or 6 With overload display	Compliant
Range structure of the current input circuit and withstand overload input	Direct input range: 0.1, 0.2, 0.5, 1, 2, 5, 10, 20, 50, and 100A ranges are desirable External sensor range: 0/1 V to 10 V are adequate. Excessive input is 1.2 times the range (continuous) and 10 times (1 s)	0.5, 1, 2, 5, 10, 20, 30 A range (when the crest factor is 3) 0.25, 0.5, 1, 2.5, 5, 10, and 15A range (when the crest factor is 6) 0.05, 0.1, 0.2, 0.5, 1, 2, 5, 10 V (when the crest factor is 3) 0.025, 0.05, 0.1, 0.25, 0.5, 1, 2.5, 5 V (when the crest factor is 6) Direct input Peak value of 90 A or rms value of 33 A, whichever is less (continuous) Peak value of 150 A or rms value of 50 A, whichever is less (1 s) External sensor input Peak value less than or equal to 5 times the range (continuous) Peak value less than or equal to 10 times the range (1 s)	Compliant in the range indicated in the left column. To make accurate measurements, pay attention to the crest factor and range selections.
Anti-aliasing filter	50 dB or higher	50 dB or higher for harmonic components up to the 40 th order at the fundamental frequency 50/60 Hz	Compliant
Window function shape	Rectangular	Rectangular	Compliant
Window width	10 cycles (50 Hz)/12 cycles (60 Hz)	10 cycles (50 Hz)/12 cycles (60 Hz)	Compliant
Relative deviation of the sampling frequency and fundamental frequency	Within ±0/03%	Within ±0/03%	Compliant
Grouping of interharmonics	Required	Grouping function available	Compliant
Smoothing	Time constant: 1.5 s	Time constant: 1.5 s	Compliant
Window gap and overlap	No gap and no overlap	No gap and no overlap	Compliant
General specifications	The effects of temperature, humidity, supply voltage, common-mode voltage, static electricity, and electromagnetic field must be specified.	See the items in the general specifications	Compliant in the range of the general specifications

Index

Symbols

–Max Error	6-13
+Max Error	6-13

A

A THDG	1-18
A THDS	1-19
About	9-6
Acquisition Data Window	3-14
active power	3-8
antialiasing filter	8-2
applicable instruments	10-1
applicable standards	1-8
Arrange Icons	9-3
average comparison	6-12
averaging	8-2

B

bar, color of	4-12
bar graph display	1-4
bar graph type	4-11

C

cascading of windows	9-1
class	3-7
Class A limits	1-8
Class B limits	1-9
Class C limits	1-9
Class D limits	1-11
classification	1-8
color	7-3
Color/Mono	7-15
comments	1-3
communication address	2-14
communication mode	2-14
comparison, number of files	6-14
crest factor	1-20
Current Peak (–)	4-25
Current Peak (+)	4-25

D

data size	6-3, 6-8, 6-10, 7-2, 7-5
Display Image	7-8, 7-11
distorted wave	1-16

E

Ethernet control, setting of	2-5
Evaluate Class	3-10
evaluation colors	4-3
evaluation graph	4-1
evaluation result, display of	1-4
exiting	2-13
extension	6-3, 6-8, 6-10, 7-2, 7-5

F

file name	6-3, 6-8, 6-10, 7-2, 7-5
files, number of	6-14
fluctuation graph display	1-4
Frequency	4-9, 4-25
functional explanation	1-1
functions	10-1
fundamental current	3-8
fundamental frequency	1-16
fundamental wave	1-16

G

GP-IB address	2-14
graphs and lists, mutual relationship of	4-12
group total harmonic distortion	1-18

H

harmonic component	1-16
Harmonic Current Bar Graph	4-5
Harmonic Current Fluctuation Graph	4-19
Harmonic Current List Window	4-16
Harmonic Current Measure Value List	4-13
harmonic group	1-18
Harmonic Measurement Mode	1-2, 3-5
Harmonic Monitor Mode	1-2
Harmonic Monitor mode	5-1
Harmonic Monitor window	5-5
harmonic order	1-16
Harmonic Phase Angle Bar Graph	4-30
Harmonic Phase Angle Measure Value List	4-32
harmonic subgroup	1-18
Harmonic Voltage Bar Graph	4-7
Harmonic Voltage Measure Value List	4-15
Harmonics Current Fluctuation Graph window	4-21
Harmonics Phase Angle Measure Value List window	4-33
Harmonics Phase Angle Value Bar Graph window	4-31
help	9-4
higher harmonic	1-16

I

IEC 61000-3-2	1-8
installation	2-7
instantaneous values	4-7
interharmonic center subgroup	1-19
interharmonic group	1-19
interharmonics	1-17

J

Judgment	4-8
----------------	-----

Index

L	Page
limits	1-8
limits, application method of	1-11
list display	1-4
list type	4-17
load	1-5, 3-17
Load Measure Data	6-4
Load Setup Information	6-4
lower power limit	3-7

M	Page
magnification	4-6
Margin	4-17
maximum comparison	6-12
Meas Time	4-8
measured data/waveform data, saving of	1-5
measured values, colors of	4-18
measurement equipment	1-11
measurement mode	1-2, 3-5, 5-1, 5-9
measurement, starting of	1-3
measurement time	1-3, 3-12
Measurement Time Setup	3-12
Mono	7-3
mutual relationship	4-22

N	Page
number of characters that can be entered	7-5

O	Page
Off-Line	3-16
Off-Line mode flow chart	1-13, 1-15
Offline	2-14
On-Line	3-3
On-Line mode	3-16
On-Line mode flow chart	1-12, 1-14
Online	2-14
Online mode	3-3
operation, flow of	1-12, 1-14
order 3 and 5	3-8
Overall Evaluation Graph	4-1
Overall Evaluation Graph Window	4-2

P	Page
percentage display	4-6
PF	4-9
phase angle, display of	4-25
phase angle, list display of	1-4
phase angles, color of	5-7
phase voltage, selection of	3-7
PLL source	1-16, 4-9, 4-25
POHC	4-10
POHC Limit	4-10
POHC Max	4-10
POHC maximum	1-20
power factor	3-8
power supply	1-11
Preview	7-8
print	1-5, 7-11
print mode	7-5
printer, setting of	7-7

R	Page
Range	4-8, 4-25
range	8-1, 8-2
Regulation	3-10
relaxation condition	4-3
repeatability of measured data	1-6, 6-11
Repeatability of Measurement Data Window	6-13
report comment	7-3
report setup	7-3
report title	7-3
reports	1-3
reports, printing of	7-15
reports, saving of	1-5
reports, title of	1-3

S	Page
save	1-5, 6-1, 6-2, 6-7, 6-9
Save Display Image (BMP)	7-1
Save Harmonic Data (CSV)	6-7
Save Measure Data	6-2
Save Report (BMP)	7-3
Save Setup Information	6-1
Save Wave Data (CSV)	6-9
scale, type of	4-6
screen image, saving of	1-5
screen images, printing of	7-15
Set Fund I	4-10
Set P	4-10
Set PF	4-10
setup information, contents of	6-5
setup information, saving of	1-5, 6-3
show/hide	4-22
Sigma W	4-10
specifications	10-1
standard	3-10
standard and measurement environment	1-3
standard and measurement environment setup	3-6
Start	3-13, 5-2
starting	2-10
Stop	3-13, 5-2
subgroup total harmonic distortion	1-19
system requirements	1-7, 10-2

T	Page
Terms and Conditions of the Software License	ii
test conditions	1-11
THC	1-16
THD	1-16
THDG	1-18
tiling of windows	9-1
time zone	4-21, 4-27

V	Page
V THDG	1-18
V THDS	1-19
View	4-1
Voltage, Current, and Electric Power Fluctuation	4-26, 4-28
Voltage Peak (-)	4-25
Voltage Peak (+)	4-25

W	Page
Wave Graph	4-23
waveform display	1-4
waveform graph	4-24
Waveform Monitor Mode	1-3, 5-9
Waveform Monitor window	5-11
WT, measurement conditions of	8-1
WT Setting	3-4
WT setting	8-1

Y	Page
Y-axis	4-6